

# Paddle Shifter User's Guide

Model PS-2000

## Included Parts List:

- 1 - Receiver Module
- 1 - Receiver Module Harness (5' length)
- 1 - Paddle Shifter Module
- 1 - Paddle Shifter Module Harness
- 1 – ½" Spacer
- 2 – ¼" Spacer
- 1 – User's Guide
- 6 – #10-32 x 2" Flat Head Cap Screw
- 1 - *Optional* Multi-Function Display Installed on Paddle Shifter

## Required Additional Items to Complete Installation:

- Vehicle Wiring Diagram
- Steering Wheel Removal Tools
- Wiring Tools
- Heat Gun
- Steering Wheel Adapters

## Pinout for Receiver Module Harness

Pin	Wire Color	Function
1	Red	Switched +12V
2	Black	Ground
3	White w/ Red	CAN H
4	White w/ Black	CAN L
5	Orange	OEM Horn Wire Switch Side
6	Gray	OEM Horn Wire Relay Side
7	Green	Downshift Output
8	Blue	Upshift Output

## Pinout for Paddle Shifter Module Harness

Pin	Wire Color	Function
1	Green	Horn Ground
2	White	Horn Switch
3	Black	Ground
4	Red	Power from Receiver Module

\*\* Note: The harnesses share common colors that are NOT the same function. When reading the instructions, do not confuse the two harnesses or assume like colors connect to each other. The receiver module harness is 5-feet long. The paddle shifter module harness is 12-inches long.

# Overview

The Powertrain Control Solutions (PCS) Paddle Shifter is used to manually shift an electronic automatic transmission. The paddle shifter kit includes a receiver module and a paddle shifter. Optionally, the paddle shifter may include a multi-function display. The paddle shifter bolts on to the steering column using the 5 or 6-bolt steering wheel pattern. Grant, Sparco, and Momo sell adapters to convert from a splined or 3-bolt steering column to the 5 or 6-bolt pattern. The paddle shifter commands a shift from the receiver module to the transmission controller using either a high-speed CAN connection or discrete outputs. The CAN connection is recommended if using a PCS transmission controller and required if using the multi-function display. The communication from the paddle shifter to the receiver module is wireless, however, power is required at the paddle shifter. To easily accommodate this requirement, PCS recommends installation using the existing horn wire as described further in this manual.

**NOTE: THIS PRODUCT IS NOT DESIGNED FOR VEHICLES WITH A STEERING WHEEL MOUNTED AIRBAG.**

Ensure all safety precautions have been taken before beginning this installation. This includes disconnecting the negative battery terminal.

## 1 Receiver Module Installation Instructions

### 1.1 Locate and connect the receiver module to the existing horn circuit.

The receiver module should be mounted in a location near the paddle shifter with access to power (switched +12V), ground, the horn circuit, and either the TCU CAN circuit or TCU digital inputs. This is typically behind the dash or in the driver's kick panel. Before permanently mounting the receiver, it is advised to verify operation of the complete system. It is possible that certain locations may result in low wireless signal quality to the paddle shifter module resulting in degraded performance. The receiver module should be securely mounted using the two bolt holes or with high strength Velcro.

The paddle shifter module mounted to the steering wheel requires power. This kit was designed to use the existing horn wire to simplify the installation. Figure 1 shows a typical stock horn circuit. Also note the wire that will need to be located and cut.

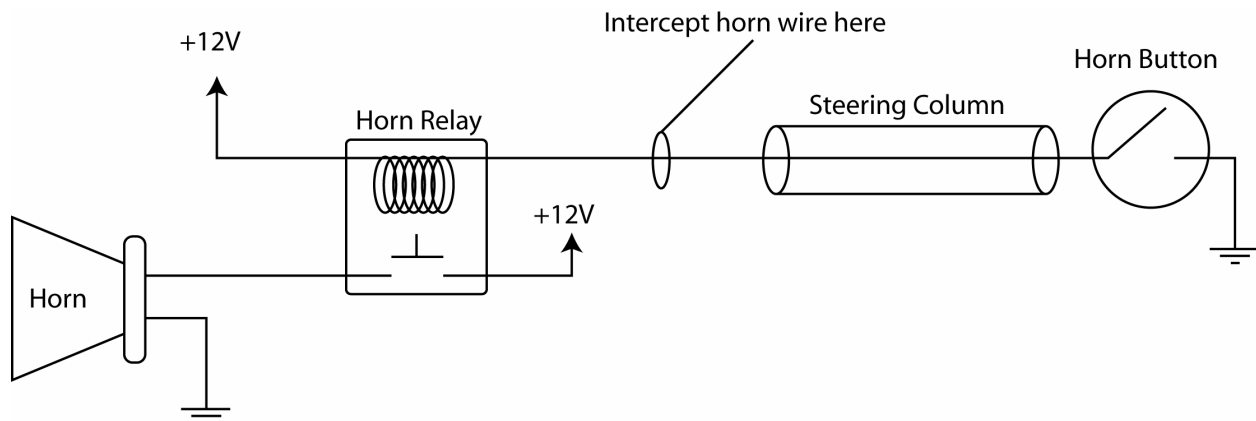

**Figure 1 - Typical OEM horn circuit**

Figure 2 shows the installation of the receiver module into the existing horn circuit. Cut the OEM horn wire before the steering column. Connect the horn relay side to the gray wire on the receiver module harness (Pin 6). Connect the horn button side to the orange wire on the receiver module harness (Pin 5). Connect the red wire

(Pin 1) to a switched +12V power source. Connect the black wire (Pin 2) to a chassis ground. Butt crimp connectors and heat shrink have been provided for this operation.

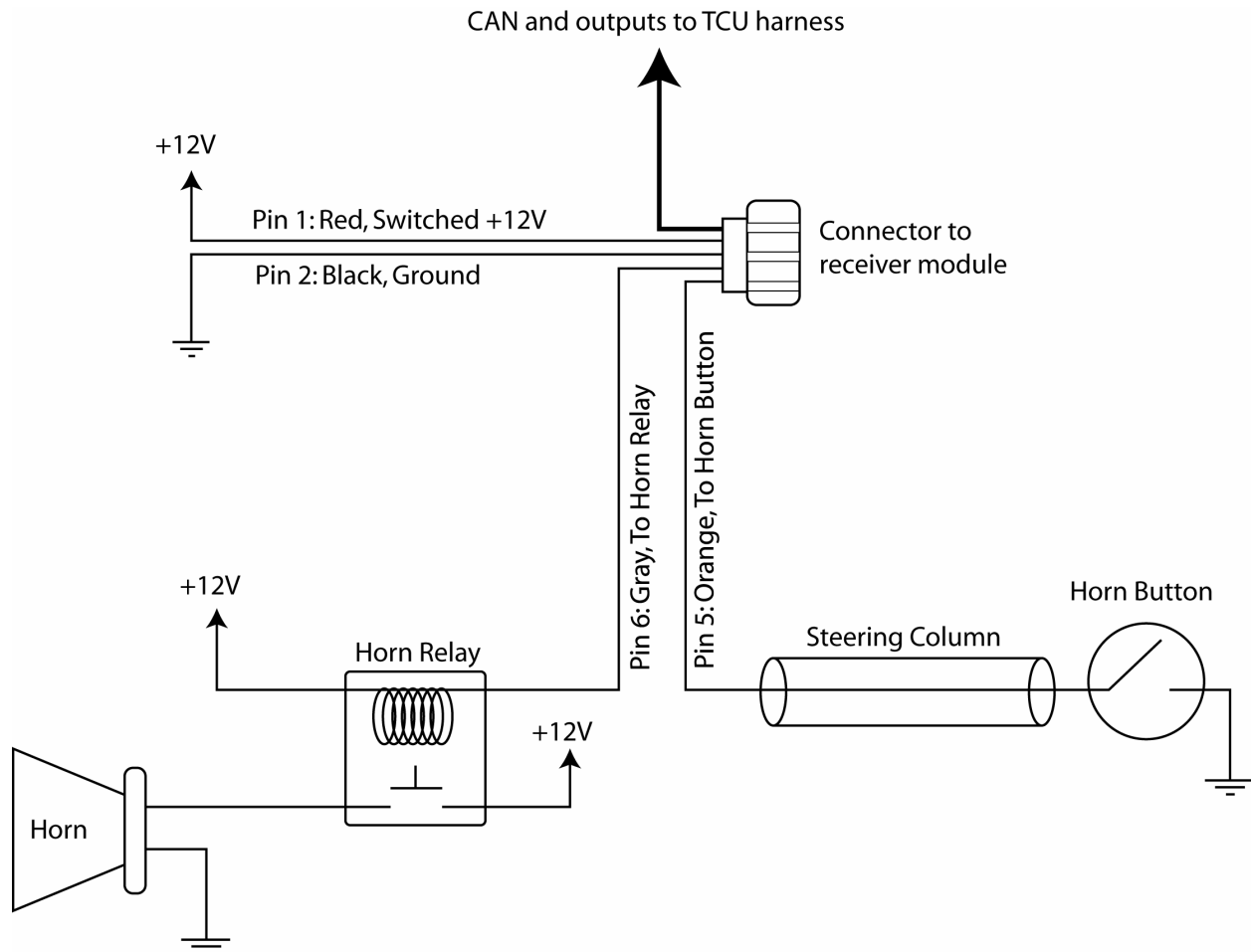

Figure 2 - Horn circuit with receiver module installed

**1.2a. Connect the receiver module to CAN for TCU communication.**

If a display is not being used and discrete outputs are going to be used to shift the controller, refer to step 1.2b.

If this is the first CAN device connected to the TCU, a CAN Master Connection Kit (Part #CON-5500) is required. If a CAN bus has already been created with a different device, then a CAN Add-on Kit (Part #CON-5501) is required. Neither CAN kit is included with the paddle shifter kit.

Insert the two-pin Deutsch connector with the twisted white/red and white/black pair into the CAN tee connector. Follow the instructions that came with the CAN kit or refer to Figure 3.

After connecting to CAN, skip step 1.2b and proceed to Section 2. This concludes the wiring at the receiver module.

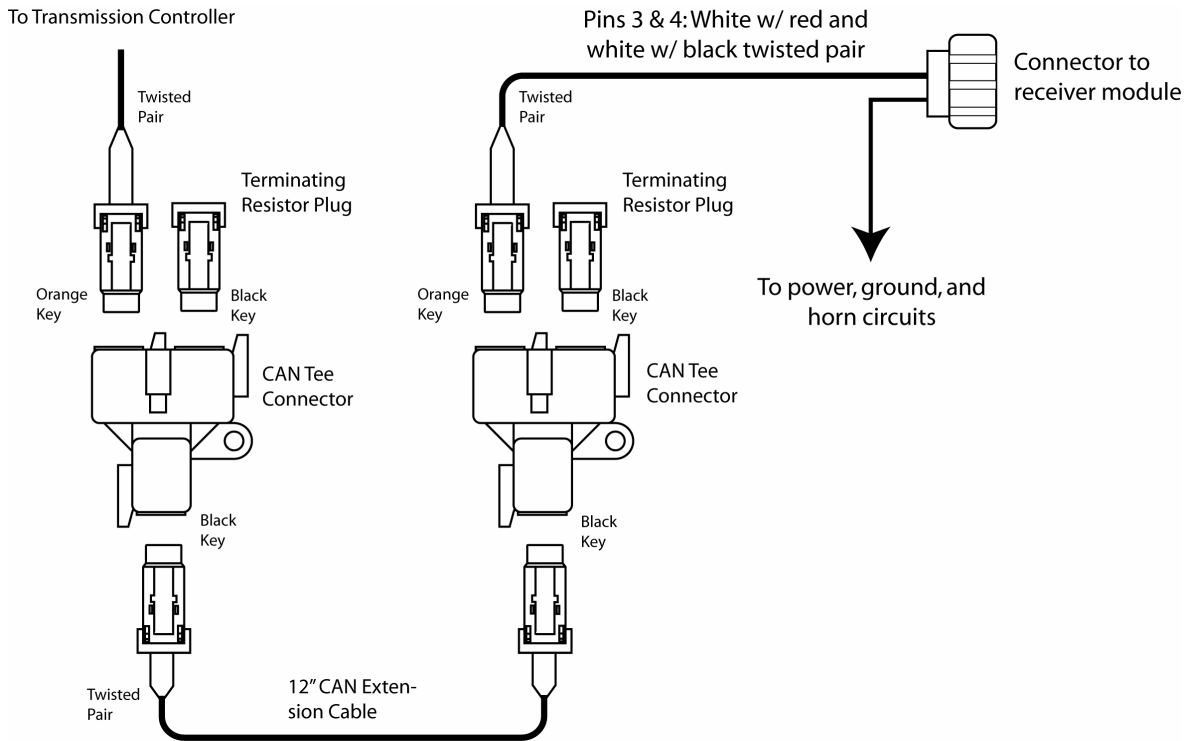
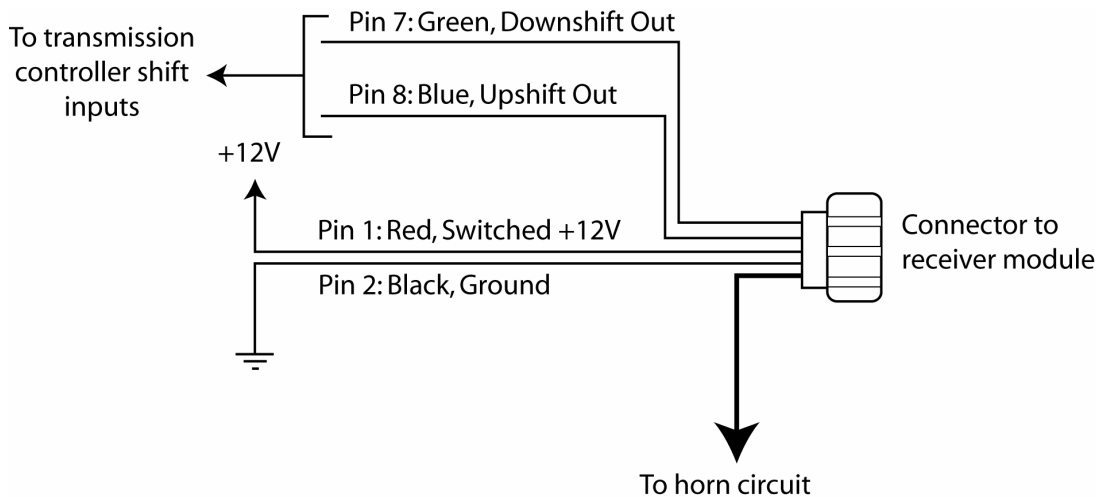

**Figure 3 - Receiver harness connected using CAN**

**1.2b. Connect the receiver module to TCU discrete inputs shifting.**

If using CAN for communication and shifting, proceed to Section 2. Do not connect both CAN communication and the digital inputs. You must choose one or the other. If using the optional multi-function display, CAN must be used for full functionality.

Connect the green wire (Pin 7) on the receiver module harness to the appropriate TCU digital input for downshifting. Connect the blue wire (Pin 8) to the appropriate TCU digital input for upshifting. This is shown in Figure 4.



**Figure 4 - Receiver harness connected using digital inputs**

This concludes the wiring at the receiver module.

## 2 Paddle Shifter Module Installation Instructions

### 2.1 Connect the paddle shifter to the horn wire.

Locate the horn wire at the top of the steering column. Connect it to the red wire (Pin 4) on the paddle shifter harness. Use provided butt crimp and heat shrink.

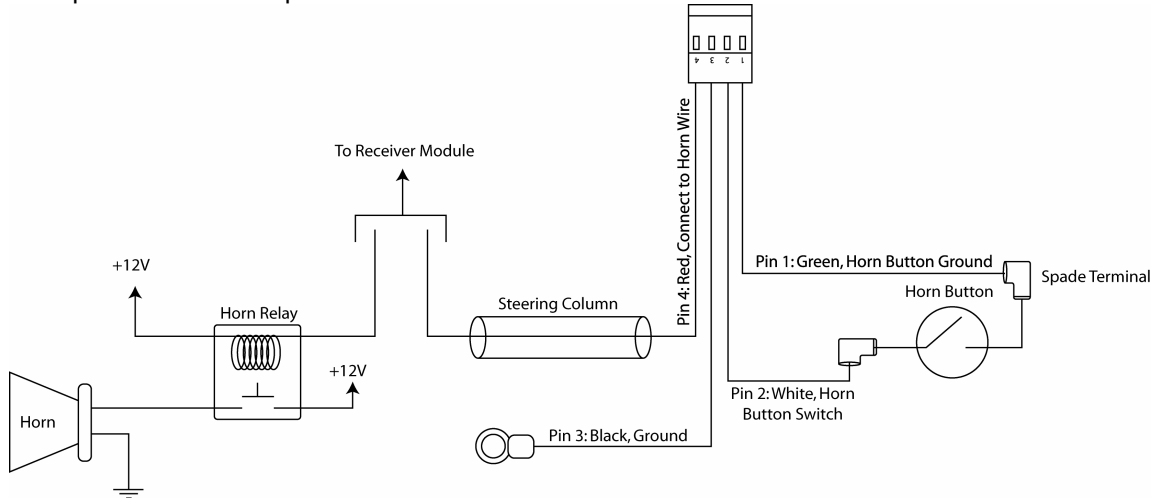

Figure 5 - Paddle shifter harness installation

### 2.2 Prepare steering column for 5 or 6-bolt wheel and ground harness.

The paddle shifter bolts on to a steering column using a 5 or 6-bolt steering wheel pattern. These patterns are typical for aftermarket steering wheels. The purchase of an adapter to convert from the stock steering column to the appropriate bolt pattern may be required. Adapters are not included in this kit. A typical installation is shown in Figure 6.

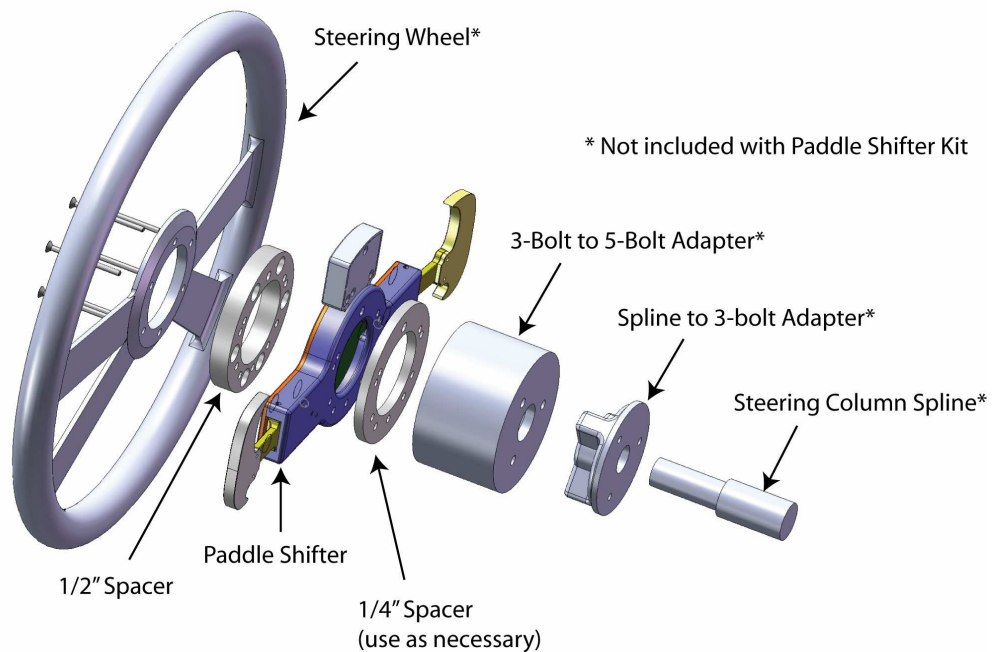

Figure 6 - Typical Installation

Follow the manufacturer's installation instructions of any adapter(s) installed on the steering column.

The paddle shifter must be grounded. The black (Pin 3) ground wire has a circular terminal installed on it for installation through a bolt. The bolt should bolt directly into the steering column to provide a clean ground.

### 2.3 Install spacers, paddle shifter, and steering wheel.

The paddle shifter kit includes one 1/2" spacer and two 1/4" spacers. The 1/2" spacer should be inserted between the wheel and the paddle as shown in Figure 6. The 1/4" spacers can be inserted on the front or back of the paddle shifter to set the distances between the steering column, paddle shifter, and steering wheel. Different combinations may be required to accommodate variances in steering wheel dish, steering column controls, and other factors.

After choosing the appropriate combination of spacers, align the installation holes of the spacers, paddle shifter, and steering wheel. Insert the 5 or 6 installation bolts through the holes and thread them into the adapter. The horn button should be removed during installation to provide access to the wiring and paddle shifter connector. Pull the green and white horn wires (with the 90 degree spade terminals installed) through the paddle shifter.

### 2.4 Connect the harness to paddle shifter and to horn button.

Connect the green wire (Pin 1) on the paddle shifter harness to the ground on the horn button. Connect the white wire (Pin 2) to the horn button switch. Spade terminals have been installed on these wires to simplify installation. Connect the 4-pin harness to the paddle shifter circuit board. The red connector has pin numbers marked. The pin numbers should face the steering wheel and pin 1 should be on the right. The connector should direct all wires to the steering column even though the horn wires are routed to the steering wheel.

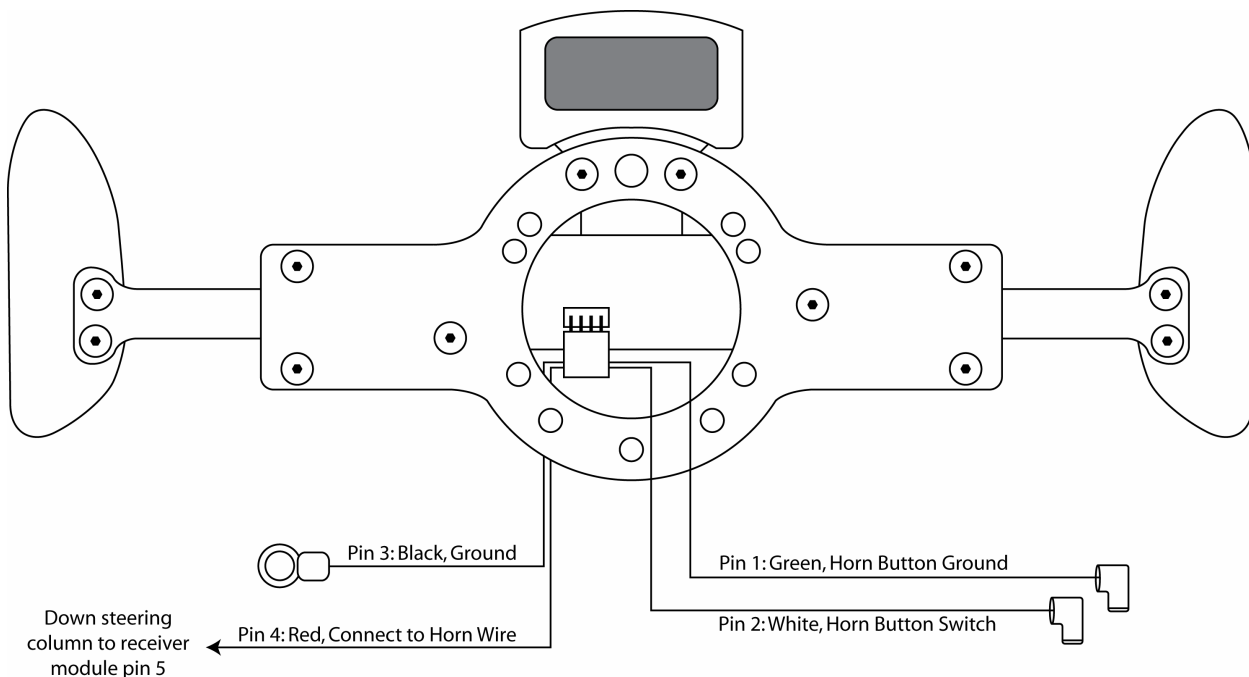

**Figure 7 - Paddle Shifter Wiring**

This concludes the installation of the paddle shifter.

### 3 PCS Transmission Controller Setup

The transmission controller must be configured for manual shifting. This includes wiring a switch for simple or true manual mode. Simple manual mode allows the user to set the top gear of the transmission, similar to moving the shifter lever down. In this mode, the transmission will upshift and downshift to the top gear as scheduled in the calibration. In simple manual mode, the transmission will automatically downshift to 1<sup>st</sup> gear as the vehicle comes to a stop. In true manual mode, the transmission will shift to the gear demanded by the paddles. True manual mode is the mode typically used with paddle shifters. In true manual mode, the transmission will not automatically downshift as the vehicle comes to a stop. It is the responsibility of the driver to downshift to the appropriate gear when the vehicle moves from a stop.

#### 3.1 TCU Configuration if using CAN for shifting and communication

If connected to the transmission controller using digital inputs instead of CAN, skip this section and proceed to Section 3.2.

In the TCU software, open the CAN Communication screen from Transmission Setup. Select PCS for the desired protocol and check transmit proprietary PCS messages as shown in Figure 8.

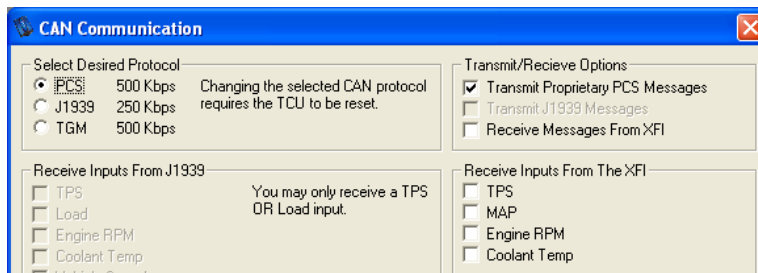

Figure 8 - TCU CAN Configuration

When using CAN to shift, verify that no digital inputs are configured for shifting. Shifting over CAN and the digital inputs may result in inconsistent shifting. Open the digital inputs form from Transmission Setup. Confirm that none of the inputs are set to Upshift or Downshift. Also, check that the input wired to the manual mode switch is defined as True Manual or Simple Manual. In the example shown in Figure 9, the true manual switch is an active low (ground) input connected to digital input 7. Note: Gear selects, brake light inputs, and other functions unrelated to manual mode shifting should not be changed from the correct base calibrations. The functions relevant to shifting are Simple Manual Mode, True Manual Mode, Upshift, and Downshift.

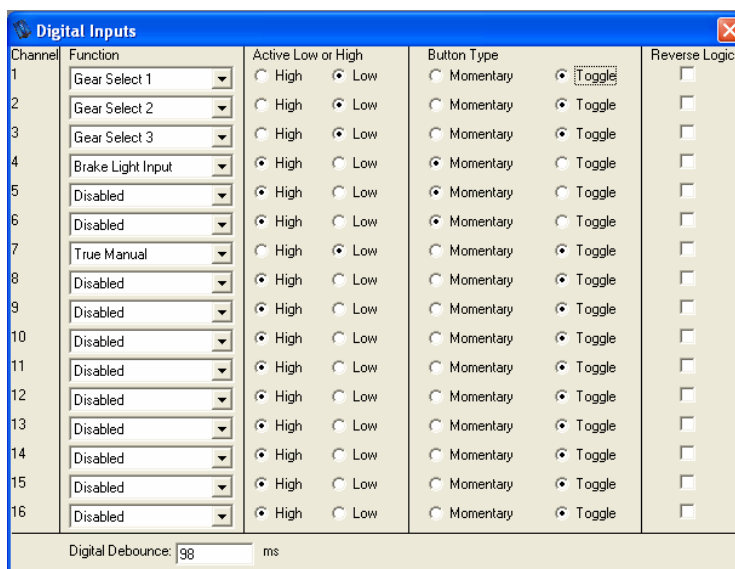

Figure 9 - TCU Digital Input Configuration

### 3.2 TCU Configuration if using digital inputs for shifting

If using CAN to communicate and shift the transmission, skip this section and proceed to Section 4.

Open the digital inputs form from Transmission Setup. Confirm that the input connected to the upshift wire is defined as Upshift. Likewise, confirm that the input connected to the downshift wire is defined as Downshift. Change the functions if they are not configured properly. Also, check that the input wired to the manual mode switch is defined as True Manual or Simple Manual. In the example shown in Figure 10, the true manual switch is an active low (ground) input connected to digital input 7. Upshift is connected to digital input 8 and downshift is connected to digital input 9. The discrete signals from the receiver module are low during a shift so the shift inputs must be configured for active low. Note: Gear selects, brake light inputs, and other functions unrelated to manual mode shifting should not be changed from the correct base calibrations. The functions relevant to shifting are Simple Manual Mode, True Manual Mode, Upshift, and Downshift.

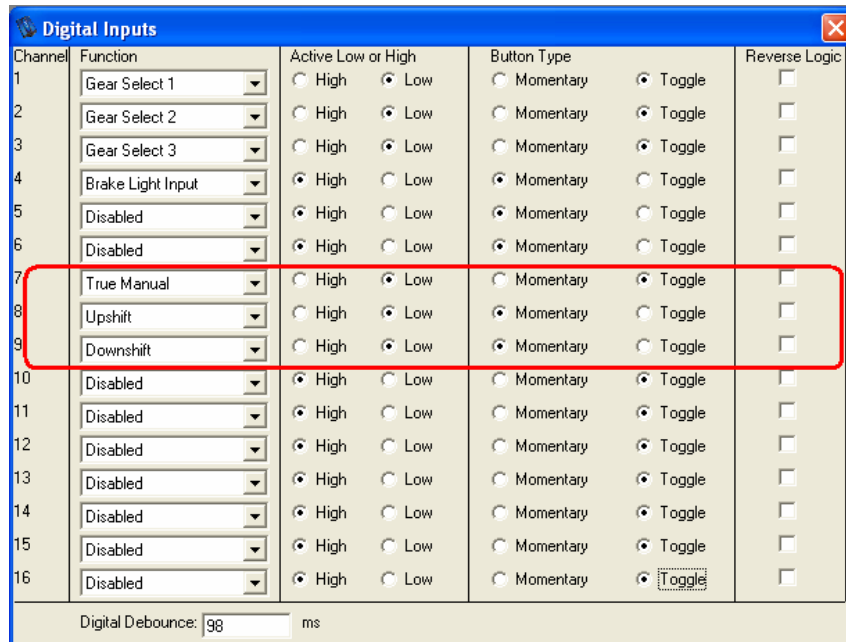

Figure 10 - TCU Digital Input Configuration

## 4 Use and Operation

With the key on and the transmission controller in manual mode, pull the right paddle to upshift and the left paddle to downshift.

The paddle shifter and transmission controller will begin the shift sequence within milliseconds. Some customers may experience a longer than desired shift delay when using the paddle shifter. The delay in the shift is present when the transmission is shifting automatically, it is just more apparent to the user in manual mode since they are starting and anticipating the shift. Some shifts may feel delayed due to low line pressure, inherent hydraulic delay in the transmission, or shift timers set too long.

If the delay is inherent in the transmission, there is nothing electronically that can be done to quicken the shift time. Modification of the valve body or installation of a shift kit may be necessary.

In many electronic automatic transmissions, increasing the line pressure during the shift may result in a firmer, faster shift. Shifts that are too firm may damage or wear other driveline components.

The programmable shift timers dictate the electronic delay between shifts. These are adjustable in the TCU software. Some transmissions must have a very specific time between shifts for the shift to execute properly.

It is recommended to use the manual mode switch to enable the True Manual Mode and Calibration B digital input function instead of just True Manual Mode in the TCU. This will allow the TCU to have one calibration with normal shifts for driving in automatic mode, and a different calibration with increased line pressure for manual mode.

**\*\*\*Consult your transmission builder or TCU tuner before making any changes to line pressure or shift timers.**

## 5 Multi-Function Display

If the paddle shifter is equipped with the optional multifunction display, a CAN connection to the TCU is required for the functions described in this section.

### 5.1 Multi-Function Display Installation

If the multi-function display is already installed in to the body of the paddle shifter, skip this section and proceed to Section 5.2.

To install a display in to the paddle shifter, begin by removing the paddle shifter from the steering column and unplugging the wiring harness if it is installed in a vehicle. Refer to Figure 11 during the installation.

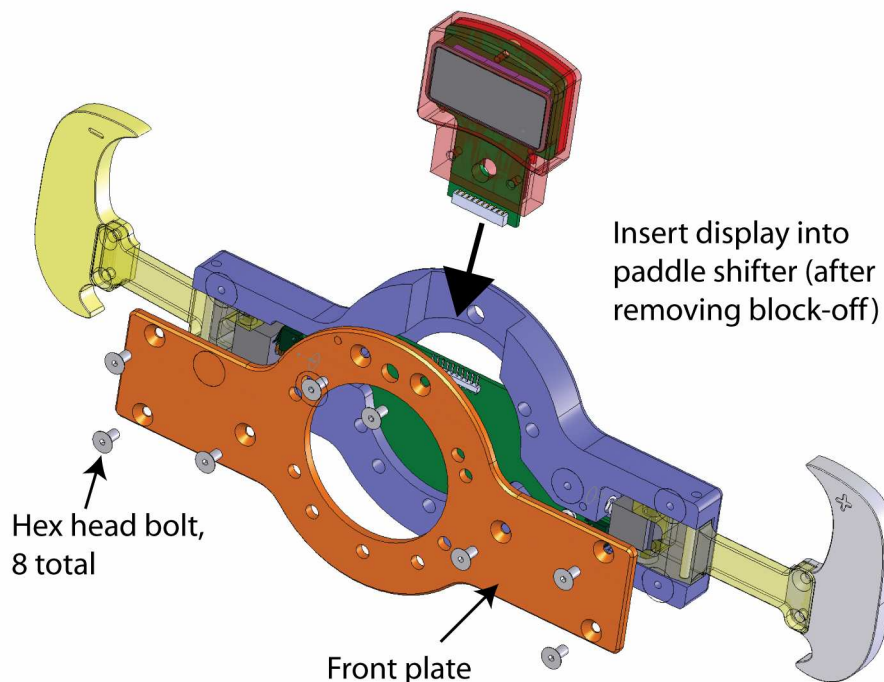

**Figure 11 - Display installation into Paddle Shifter**

1. With the paddle shifter laying flat with the front of the paddle shifter facing up, remove the 8 hex head screws.
2. Remove the front plate.
3. Remove the top block-off block that is inserted in the display location.
4. Insert the display into the paddle shifter body. The display's connector should insert into the mating connector on the circuit board. Push the display until the two bolt holes are aligned with the bolt holes on the paddle shifter.
5. Replace the front plate.
6. Insert and tighten the 8 hex head bolts.
7. Install the paddle shifter on the steering as previously described in this manual.

## 5.2 Multi-Function Display Operation

When the paddle shifter turns on, it will perform an LED test, and then scroll PCS. It will then display current gear. Pressing the button on the rear of the display will recall the name of the item that is currently monitored. Pressing the button while the name is being scrolled across the screen will cycle through the following items:

- Current Gear
- Throttle Position %
- Vehicle Speed
- Manifold Pressure
- Coolant Temperature
- Transmission Temperature
- TCC Lockup %
- Line Pressure %
- Engine RPM / 10
- Torque Converter Slip
- Transmission Slip
- Driveshaft RPM /10
- Turbine RPM /10
- Lever Position
- Display Off

The units for vehicle speed, manifold pressure, and coolant and transmission temperature are selectable from the TCU software. The current unit selected will be displayed at the end of the item name.

During a shift, the display will display current gear for two seconds and then return to the displayed parameter.

## 6 Troubleshooting

### 6.1 The display resets when the wheel is turned.

This is an indication that the wiper in the steering column is losing contact while the steering wheel is turned. This is common in older vehicles. Clean the wiper arm using Scotch-Brite or a similar material. Also check and possibly adjust the tension of the wiper arm.

### 6.2 Horn sounds when installing the horn button into steering wheel or when key is turned on.

The white wire on the paddle shifter harness is connected to the horn button ground connector instead of the switch connector. On the horn button, switch the white and green wire.

### 6.3 Transmission shifts but displays “No TCU Found”.

The display will display “No TCU Found” when the receiver module does not receive a valid CAN message from the transmission controller. Verify the wiring as discussed in Section 1.2a. Failure to use two termination resistors is a common problem that will result in this situation. Also, verify the CAN setup is configured properly as discussed in Section 3.1.

### 6.4 Slow shifts or delayed shifts.

The paddle shifter and the transmission controller will electronically start the shift in a fraction of a second. In most cases, the delay is associated with low line pressure, inherent hydraulic delay in the transmission, or shift timers set too long. Refer to section 4 for a discussion about shift delay.

### 6.5 Transmission will not shift with the paddles.

Verify power to the paddle shifter. If the paddle is equipped with the optional display this can be verified by the display turning on. If the paddle shifter is not equipped with the display, measure the voltage between pin 1 and pin 2. If this is approximately 12V (battery voltage) then there is power at the paddle shifter.

If power is confirmed at the paddle shifter, check shift communication with the laptop. Connect the laptop to the transmission controller. First verify the transmission controller is in manual mode. This can be seen on the monitor screen in the current modes section as shown in Figure 12 (lower circle). If the manual mode input has been defined as Simple Manual, then the Simple Manual mode should be turned on instead. Then verify the range of the transmission is Drive or a high gear that will allow upshifting.

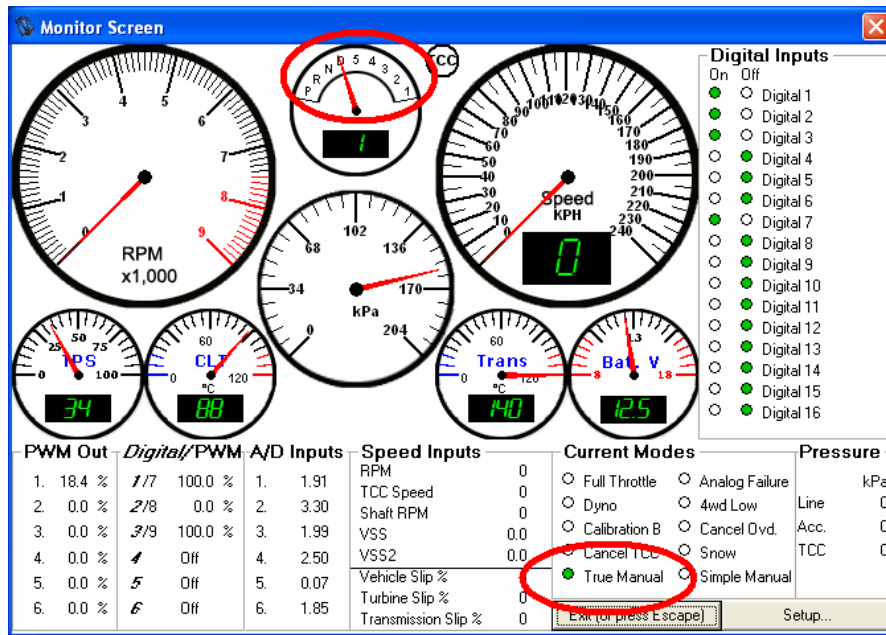

Figure 12 - TCU Monitor Screen

If using discrete inputs for shifting, verify the digital input are configured as described in Section 3.2. From the monitor screen, you should see the digital inputs switch to On briefly, during the shift.

If using CAN for shifting, verify the CAN is configured as described in Section 3.1.

### 6.6 Display turns on, displays values most of the time, but will occasionally go blank.

The display will go blank or display “Wireless Error” when it does not receive a message from the receiver module. If the display only drops out occasionally, the problem is probably related to wireless interference. Move the receiver module closer to the paddle shifter.

### 6.7 Display turns on, scrolls PCS and then goes blank.

See Troubleshooting Tip #6.6 resolution.

### 6.8 Display shows “Wireless Error” when a paddle is pulled.

See Troubleshooting Tip #6.6 resolution.