

# TEC GT Adapter Harness

Part #DIS-4110

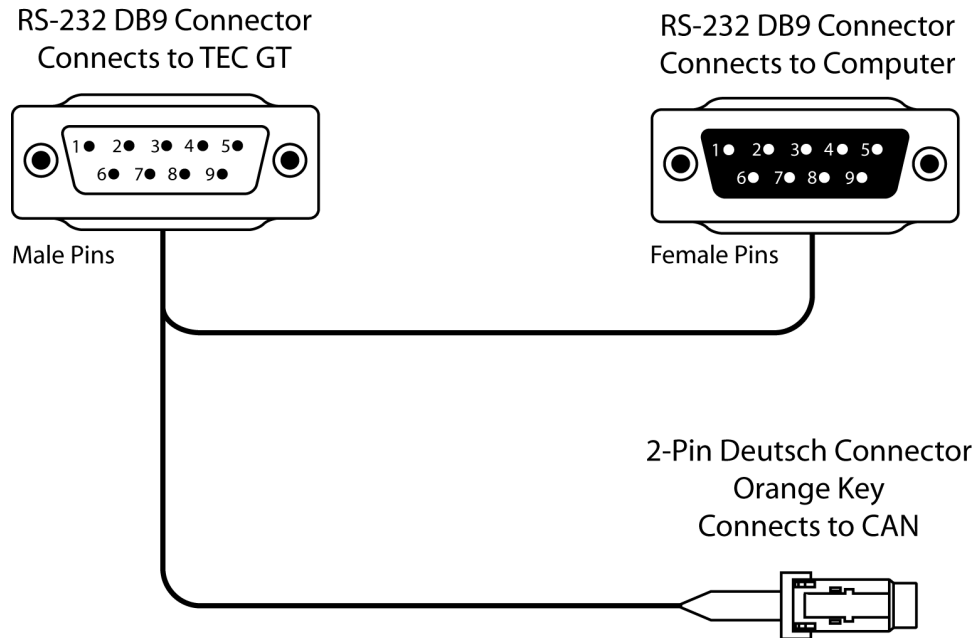

The TEC GT Adapter Harness is used to connect an Electromotive TEC GT ECU to the CAN bus. This harness connects to the serial port on the TEC GT and splits to a CAN Deutsch connector and a DB9 serial connector. This harness is shown below.



The pinout for this harness is shown in the table below. All pins not listed below are not connected on the TEC GT Adapter harness.

TEC GT DB9 Pin	Computer DB9 Pin	CAN Pin	Function	Color
1	NC	A	CAN High	White with Red Stripe
2	2	NC	TEC GT Transmit	Black
3	3	NC	TEC GT Receive	Red
4	NC	B	CAN Low	White with Black Stripe
5	5	NC	TEC GT Serial Ground	Bare

Once the TEC GT is connected to CAN, it must be enabled on the D200. To enable a serial device from the D200 Main Menu, select **Communications** then **CAN-A** and select **TEC GT**. Select **Back** to save the settings. You will also have to choose the data you wish to monitor by selecting **Monitor Settings** then **Set Display Data** from the D200 Main Menu. If you are going to **Data Log** the TEC GT, select **Data Log Settings, Sources**, then **Comm Inputs** to choose the desired data log rate.