

PCS Clutch Speed Sensor Kit User Guide

Kit Contents

- 1 - Stainless Threaded Body Hall-Effect Omni-Polar Speed Sensor with Internal Pull-up Resistor
- 2 - Magnets
- 1 - 1/4" Cobalt Drill Bit
- 1 - Harness with 4-pin CPC Mate to Speed Sensor Connector, 10-Foot length, Unterminated End

If any of the above items are missing, please contact Powertrain Control Solutions.

Two sensors are available. These are listed below

Kit Part Number	Sensor
SNS-5500	3/8"-24
SNS-5501	5/16"-24

Installation

Measure the distance from the outside of the bellhousing to the center of the sensor hole in the candlestick as shown in the figure. Mark this distance on the input shaft of the transmission. Drill a 0.325" deep hole in the input shaft (drill bit included with kit) so the magnet will sit flush in the shaft. Epoxy the magnet in the hole. Only one magnet is required, one extra magnet is provided in the kit. Screw the sensor into the threaded hole in the candlestick. The sensor should be flush with the inside of the candlestick but not protruding into the inner hole.

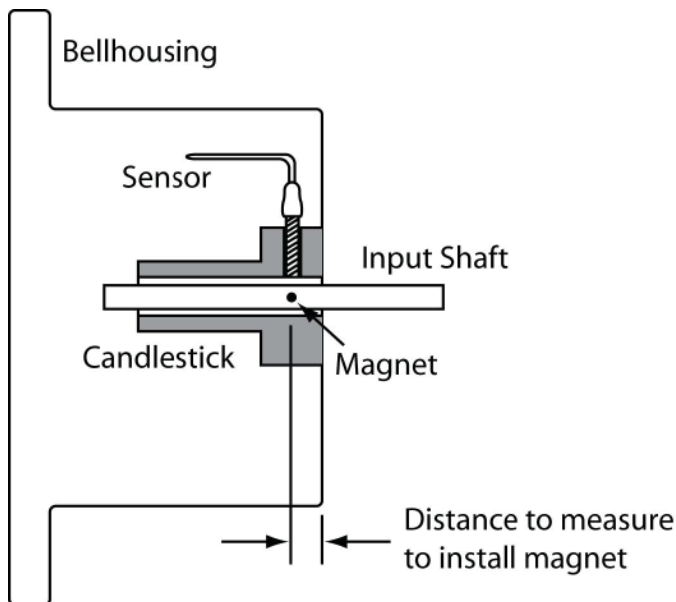

Electrical Connection

The mate to the clutch speed sensor is a 4-way circular plastic connector. The connector and wires are included with the purchase of a sensor. Additional connection kits are available from PCS.

The pinout of the speed sensor is shown on the following page.

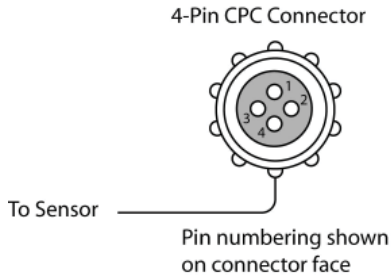

Pin	Function	Wire Color
1	+5V Supply	Red
2	Sensor Output	White
3	Sensor Ground	Black
4	Shield	Bare Metal

NOTE: The speed sensor contains a 2200-ohm internal pull-up resistor between power supply (Pin 1) and sensor output (Pin 2).

NOTE: The sensor will trigger from either north or south pole magnets.

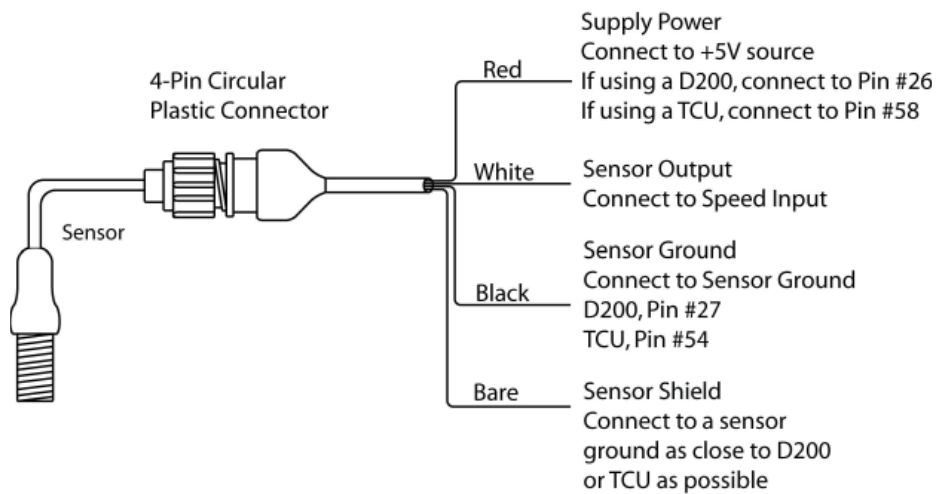

Replacement Parts

This kit includes everything to measure shaft rotation. If replacement magnets or sensors are needed, they can be ordered with the part numbers shown below.

- Magnet Kit - Part #SNS-5010
- Stainless 3/8"-24 Threaded Body Hall-Effect Omni-Polar Speed Sensor with Internal Pull-up Resistor and two 3/8"-24 Nuts - Part #SNS-5000
- Stainless 5/16"-24 Threaded Body Hall-Effect Omni-Polar Speed Sensor with Internal Pull-up Resistor and two 5/16"-24 Nuts - Part #SNS-5005

LIMITED WARRANTY STATEMENT. Powertrain Control Solutions, LLC. Warrants all merchandise against defects in factory workmanship and materials for a period of 12 months after purchase. This warranty applies to the first retail purchaser and covers only those products exposed to normal use or service. Provisions of this warranty shall not apply to Powertrain Control Solutions, LLC. Product used for a purpose for which it is not designed, or which has been altered in any way that would be detrimental to the performance or life of the product, or misapplication, misuse, negligence or accident. On any part or product found to be defective after examination by Powertrain Control Solutions, LLC., Powertrain Control Solutions, LLC. will only repair or replace the merchandise through the original selling dealer or on a direct basis. Powertrain Control Solutions, LLC. assumes no responsibility for diagnosis, removal and/or installation labor, loss of vehicle use, loss of time, inconvenience or any other consequential expenses. The warranties herein are in lieu of any other expressed or implied warranties, including any implied warranty of merchantability or fitness, and any other obligation on the part of Powertrain Control Solutions, LLC., or selling dealer.