

Automatic Transmission Controller



www.TransmissionController.com



Instruction Manual

Version 2.1

January 18, 2006

Powertrain Control Solutions, LLC.
10511 Old Ridge Rd.
Ashland, VA 23005

Phone: (804) 227-3023
Fax (804) 227-3005

www.powertraincontrolsolutions.com

Table of Contents

Coverpage.....	1
Table of Contents.....	2
1. Introduction to Electronic Automatic Transmission Control.....	4
2. How the TCU Works.....	5
3. Chapter 1 – Installation.....	6
3.1 Planning & Research.....	6
3.2 Connectors.....	7
3.3 Inputs.....	9
3.3.1 Digital Inputs.....	9
3.3.2 Analog Inputs.....	10
3.3.3 Speed Inputs.....	11
3.3.4 Power and Ground Connections.....	12
3.4 Outputs.....	12
3.4.1 Digital Outputs.....	12
3.4.2 PWM Outputs.....	13
3.4.3 Speed Output.....	13
3.5 Extra Features.....	13
3.6 Communication.....	14
3.7 TCU Location and Wire Routing.....	14
3.7.1 General Wiring Hints.....	14
3.8 Final Steps.....	15
3.8.1 Find and wire necessary sensors.....	15
3.8.2 Wire power and ground connections.....	15
3.8.3 Install the TCU and route the wiring harness.....	15
3.8.4 Double check your installation.....	16
3.8.5 Communication.....	16
3.8.6 Start it up!.....	16
4. Chapter 2 – Software.....	17
4.1 Planning & Research.....	17
4.2 Background.....	17
4.3 Overview.....	18
4.4 Software Installation.....	18
4.5 Communication.....	19
4.6 File Management.....	20
4.7 Software Walkthrough.....	20
4.7.1 Working with calibration files.....	20
4.7.2 Online Mode vs. Offline Mode.....	20
4.7.3 Transmission Setup.....	21
4.7.5 Calibration/Tuning.....	27
4.8 Additional Features.....	34
4.8.1 Stepper Motor Setup.....	34
4.8.2 Datalogging.....	34
4.8.3 Flash Upgrade Procedure.....	36
4.8.4 Com Port Manual Configuration (for Flash Upgrading Only).....	36

4.8.5 Diagnostic Trouble Codes	37
4.8.6 Password Protection	37
4.8.7 Monitor Screen	38
4.8.8 Lightweight Monitor Screen	38
4.8.9 Test Mode	38
4.8.10 Toolbar Setup	38
4.8.11 Units Selection	39
4.8.12 Tire Diameter Wizard	39
4.8.13 Sensor Calibration Wizard	39
5. Chapter 3 – Software Function List	40
5.1 Overview	40
5.2 Inputs	40
5.2.1 Analog Inputs	40
5.2.2 Digital Inputs	48
5.2.3 Speed Inputs	51
5.2.4 Frequency Range Switch	52
5.3 Outputs	52
5.3.1 Digital Outputs	52
5.3.2 PWM Outputs	54
5.4 CAN Communication	58
6. Software Hotkey List	59
6.1 Active from all menus	59
6.2 Active only from tables/charts	59
6.3 Active only from datalog viewer software	59
7. Wire Harness Diagram	60
8. Circular Plastic Connector Pinout	62
9. Backshell Removal Instructions	63
10. Glossary of Terms	71
11. Full Transmission Controller Specifications	77
11.1 Outputs	77
11.2 Inputs	78
11.3 Communication	78
11.4 Operating Conditions	79
11.5 General	79
12. Terms and Conditions	80
13. Index	82

1. Introduction to Electronic Automatic Transmission Control

Electronics are playing an increasingly important role in the modern automobile. Electronics provide the complex control needed to meet consumer demands for improved performance, safety, emissions and reliability. This trend towards electronic control has been especially strong in recent years, expanding from simple devices like power windows, locks and simple engine management to complex systems incorporating electronic throttle control, integrated engine and transmission management, and vehicle dynamic control. This trend shows no signs of abating and will likely lead to vehicles that forms a hybrid mechanically driven/electronically controlled architecture.

Electronic automatic transmissions have been shifting from purely hydro-mechanical controls to electronic controls since the early 1990's. Since then, development has been iterative and today designs exist from several stages of electronic automatic transmission control development. Our company is notably separated by the competition because of the ability for the Universal Automatic Transmission Controller (TCU) to control any transmission along these stages of electronic automatic transmission development. The required sophistication to control modern electronic automatic transmissions as well as early electronic automatic transmissions places PCS at the forefront of aftermarket transmission control.

The evolution of the modern automatic transmission and the integration of electronic controls have allowed great progress in recent years. The modern automatic transmission is now able to achieve better fuel economy, reduced engine emissions, greater shift system reliability, improved shift feel, improved shift speed and improved vehicle handling. The immense range of programmability offered by the TCU allows the modern automatic transmission to be used in everything from stock applications to road/drag race applications to street rod applications with appropriate transmission characteristics for each application.

2. How the TCU Works

An automatic transmission is a relatively simple device in theory. It simply takes power from your engine and applies this power to your driving wheels. Automatic transmissions use fluid to operate the internal mechanisms required for shifting. In the past, information was sent to the fluid control mechanism (valve body) through mechanical and pneumatic hardware. The valve body would then make a decision about when to shift, what gear to shift into and how quickly to shift. Once the valve body made these decisions, it simply altered the fluid flow and fluid pressure to implement its decision. This system required complex fluid flow logic but demonstrated high reliability and performance. Only recently has the automatic transmission undergone dramatic change after roughly a half-century of use.

Though you may not believe it, the electronic controls used to manage your transmission are equally simple in theory. To operate, your TCU must have several pieces of information sent to it so that it can decide when to shift, what gear to shift into and how quickly to shift. Once the TCU makes these decisions, it simply alters the fluid flow and fluid pressure to implement its decision. This system still relies on valve body logic in part and will still maintain some functions without an electronic controller.

The primary factor separating the modern electronic automatic transmission from yesterday's hydro-mechanical automatic transmission is the speed and complexity of the logic used for transmission behavior. The hydro-mechanical automatic transmission of yesterday could only make its decisions based on throttle position, engine load and driveshaft speed. Whereas the TCU can use these inputs as well as torque converter speed, engine speed, wheel speeds, traction control parameters, electronic throttle position, fluid temperature, engine temperature, brake pedal actuation, forward and lateral acceleration as well as several other parameters. The TCU can also utilize manual shifting operation and provide altered transmission behavior for special conditions (road race, drag race, dynamometer, snow, towing, etc.).

3. Chapter 1 – Installation

3.1 Planning & Research

Planning and research is the first step in the proper installation of the Automatic Transmission Controller (TCU). Every installer will first need to determine the make, model and year of the transmission application (ex. GM 4L60E 1996). Components like connectors, solenoids and wire colors may change by year and vehicle application. Custom wiring harnesses and documentation are available for most common applications.

If a custom wiring harness is unavailable for your application, you will need to locate the appropriate connectors and a good wiring diagram for your application. You will also need to determine the shift logic of your transmission. For a good shift logic example, please see *Table 1*. New custom wiring harnesses are always being developed; if you have questions about your application please check our website for more information.

Table 1. 4L60E shift logic chart.

Range Lever Position	Gear	Shift Solenoids (output)		Pressure Switches (input)		
		“A”	“B”	“A”	“B”	“C”
Park		ON	ON	OFF	ON	OFF
Reverse		ON	ON	ON	ON	OFF
Neutral		ON	ON	OFF	ON	OFF
OD	1 st	ON	ON	OFF	ON	ON
	2 nd	OFF	ON			
	3 rd	OFF	OFF			
	4 th	ON	OFF			
D	1 st	ON	ON	OFF	OFF	ON
	2 nd	OFF	ON			
	3 rd	OFF	OFF			
2	1 st	ON	ON	OFF	OFF	OFF
	2 nd	OFF	ON			
1	1 st	ON	ON	ON	OFF	OFF
	2 nd	OFF	ON			

The shift logic of an automatic transmission alone will not provide enough information to wire and properly program the TCU. You must also determine whether your gear selection inputs are active high (power connection applied) or active low (ground connection applied). You must also determine whether your solenoid outputs are active high or active low. A good wiring diagram will help you determine if there are additional inputs or outputs that require control and whether they are active high or active low. For a good example wiring diagram, please see *Figure 1*.

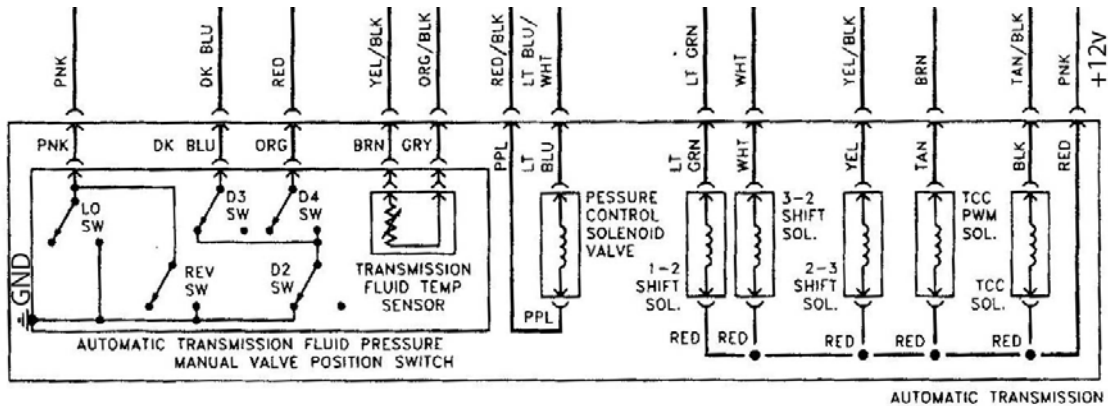

Figure 1. Typical GM 4L60E diagram for a 5.7L V8 in a 1999+ Camaro/Firebird.
 This wiring diagram is typical of an inexpensive Haynes manual.

As Figure 1 demonstrates, even an inexpensive Haynes manual can be used for planning out the installation of your TCU. By looking at the “Automatic Transmission Fluid Pressure Manual Valve Position Switch” in Figure 1 you should be able to determine that all three of the pressure switch inputs are active low. The switches are active low because when they close, they are connecting to ground. This connection to ground is shown by the multiple lines in a triangular shape on the left side of Figure 1. By looking at the solenoids of Figure 1 you should be able to determine that all the solenoids on the common red wire (going out of the unit as pink) are active low solenoids. They are active low because they are normally provided with power by the red wire and require a ground connection on each individual wire to be activated. In some transmissions, you can wire the pink wire (connecting to the red wire internally) to ground so that these solenoids become active high.

Figure 1 does not provide enough information to determine which solenoids are “A” and “B”. Figure 1 also provides no information about the solenoid control methods used and no information about the solenoid logic. Further documentation would need to be used to determine that the “1-2 shift solenoid” is solenoid “A” and the “2-3 shift solenoid” is solenoid “B”. Additional documentation would need to be used to determine that the “Pressure Control Solenoid Valve” and the “3-2 shift solenoid” are PWM.

3.2 Connectors

There are typically two to four connectors plugged into an electronic automatic transmission. One or two 2-pin or 3-pin connectors are typically used for speed measurement. Most electronic automatic transmissions will have one 2-pin or 3-pin connector for driveshaft speed. Some newer electronic automatic transmissions also use a 2-pin or 3-pin connector to measure torque converter speed.

One or two large connectors are typically devoted to the electronic solenoids and the transmission lever position detection. The electronic solenoids select the current gear, shift firmness and shift speed. The transmission lever position tells the transmission controller what gear the user has selected.

As an example, the GM 4L60E transmission has only two connectors. A 2-pin connector is used for driveshaft speed on the 4L60E. A 13-pin connector is used to drive the electronic solenoids, determine transmission lever position and monitor transmission fluid temperature.



Figure 2. GM 4L60E VSS connector



Figure 3. GM 4L60E main connector

As a secondary example, the Toyota A650E uses four connectors. A 2-pin connector is used to monitor driveshaft speed. A second 2-pin connector is used to monitor torque converter speed. A 12-pin connector is used to control electronic solenoids and monitor transmission fluid temperature. A 9-pin connector is used to determine current transmission position and houses a neutral safety switch circuit.



*Figure 4. Toyota A650E
12-pin solenoid connector*



*Figure 5. Toyota A650E 9pin
lever position connector*



Figure 6. Toyota A650E driveshaft and torque converter speed 2-pin connectors

3.3 Inputs

The number of inputs necessary will depend upon your transmission and how many additional features you wish to use. A basic set of inputs and how to properly install them will be covered in this section of the manual.

3.3.1 Digital Inputs

The TCU has sixteen digital inputs which are provided for simple on/off devices. An important function of the digital inputs is gear selection. Most transmissions require several digital inputs be wired to the transmission or lever position switch to determine which gear the driver has selected. A brake light input is another important use of a digital input. When activated, this input will unlock the torque converter clutch (TCC). Additional on/off inputs may include buttons for mode switching (performance mode, tow mode, manual mode, etc).

Each digital input has five parameters to consider: Function, active high or active low, button type (momentary or toggle), and reverse logic. This programmability allows the user to wire the digital inputs in almost any configuration or with almost any type of switch and still function properly. Select active high for inputs that are on when power is applied. Select active low for inputs that are on when ground is applied. Select momentary for buttons that are depressed for a short time period before returning to their original state. Select toggle for buttons that are depressed or moved and stay in their position until moved again. Select reverse logic for buttons or switches that are active when neither power nor ground is applied and inactive when power or ground is applied. For a complete list of digital input options, please refer to chapter 3.

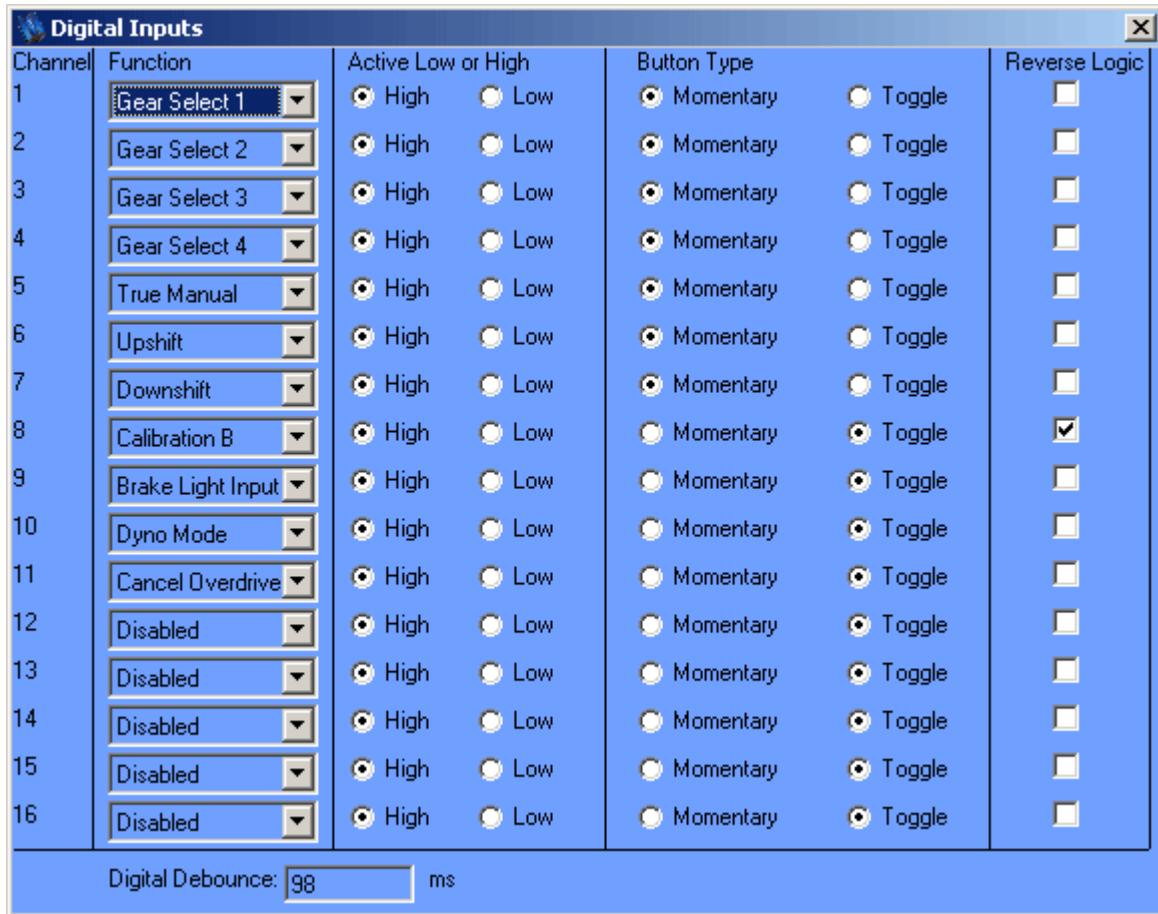

Figure 7. Digital Input Setup Chart.

3.3.2 Analog Inputs

The TCU has six analog inputs which read a 0-5v scaled input. Analog inputs are important for a variety of sensors such as throttle position (TPS), Manifold Absolute Pressure (MAP), Engine Coolant Temperature (CLT) and Transmission Fluid Temperature (TFT). An analog input can also be used with stock steering wheel buttons, like cruise control and volume control, of some vehicles where different buttons correspond to different voltages. An example wiring layout is shown in *Figure 23 & 24*. These voltages can be programmed to perform upshifting and downshifting when in manual mode.

Analog inputs 1-4 have been designed so that they can piggyback any sensor from an engine controller or directly measure most sensors. Analog inputs 1-4 should not be used to directly measure any temperature sensors or other resistance based 2-wire sensors. Analog inputs 5-6 have been designed so that they can measure any sensor directly. Analog inputs 5-6 should not be used to piggyback any sensors from an engine controller. Analog inputs 5-6 should be used to directly measure any temperature sensors or other resistance based 2-wire sensors. The proper usage for analog inputs 1-6 is visually represented in *Table 2*. For a complete list of analog input options, please refer to chapter 3.

Table 2. Analog Input Matrix.

	Analog Inputs					
	1	2	3	4	5	6
Use to piggyback any sensor from engine controller.	•	•	•	•		
Use to measure any sensor directly except temperature sensor or other resistance based 2-wire sensors.	•	•	•	•		
Use to measure any sensor directly.					•	•
Use to measure temperature sensors or other resistance based 2-wire sensors directly.					•	•

3.3.3 Speed Inputs

The TCU has four speed inputs which will interpret an incoming signal from a speed sensor. The most important function of speed inputs is to determine driven wheel speed. At least one speed sensor is required to determine driven wheel speed. Additional speed inputs may be used for measuring engine RPM, TCC speed, driveshaft speed or non-driven wheel speed. The TCU has been designed to accommodate as many speed sensor types as possible, including both magnetic (2-wire) and hall-effect speed sensors (3-wire).

The only required speed input is driven wheel speed; however the flexibility of the TCU allows even this value to be calculated. To calculate driven wheel speed, you must have driveshaft RPM, driven tire diameter and final drive ratio. Non-driven wheel speed, engine RPM and driveshaft RPM must be measured directly. Torque converter RPM can be directly measured or calculated. You must connect the positive side or output wire of each speed sensor to the respective speed input. If you these wires are reversed you may not receive the proper signal.

To accommodate a wide range of speed sensor applications, speed input trigger levels and filter values are programmable. This trigger level and filtering programmability helps eliminate false triggering in a noisy environment or no triggering with a low speed or weak signal. Though this parameter can be difficult to understand and deal with, it allows the TCU to accommodate nearly all available sensors. For a complete list of speed input options, please refer to chapter 3.

Table 3. Speed Input Matrix.

	Directly measurable	Can be Calculated	Parameters for direct measurement	Parameters for calculation
Engine RPM	•		# of Cylinders	NA
TCC Speed	•	•	# of teeth	Gear Ratios Driveshaft Speed
Driveshaft Speed	•		# of teeth	NA
Driven Wheel Speed	•	•	#of teeth	Driveshaft Speed Final Drive Tire Diameter
Non-Driven Wheel Speed	•		#of teeth	NA

3.3.4 Power and Ground Connections

The TCU requires an active power and ground connection to operate correctly. The power connection to the TCU should be switched (only turns on when you turn the ignition key to the start/run position). If you wire the TCU to a constant power source, you risk **severe** damage to the TCU and your transmission. The power source should be protected with a 10amp fuse (this can vary based on the transmission application). Your switched power source should also be capable of providing at least 10 amps (or more depending on your transmission application) and should come from a clean terminal or wire. If you splice into a wire or create a switched power junction, please protect and seal the wire or joint with sealant type heat shrink or something similar to ensure reliability. Your ground connection should be wired to a clean ground terminal on the vehicle (preferably on the transmission or engine).

3.4 Outputs

The number of outputs necessary will depend upon your transmission and how many additional features you wish to use. A basic set of outputs and how to properly install them will be covered in this section of the manual.

3.4.1 Digital Outputs

The TCU has six digital outputs which are provided for simple on/off devices. Three of these digital outputs may also be configured as PWM Outputs. An important function of digital outputs is shift solenoid operation. Several PWM or digital outputs are typically wired to the transmission to actuate the shift solenoids for proper automatic transmission operation. Some transmissions also require a digital output for Torque Converter Clutch (TCC) actuation. Digital outputs may be used to light indicators for manual mode, snow mode, TCC lock/unlock, calibration B, etc.

Each digital output has two parameters to consider: Function and active high or active low. This programmability allows the user to wire the digital outputs in almost any configuration or with almost any type of digital device and still function properly. Select the digital output function based on what you want this digital output to do. Select an output type of ground for

devices that require a ground connection to activate. Select an output type of 12 volts for devices that require a power connection to activate. For a complete list of digital output options, please refer to chapter 3.

3.4.2 PWM Outputs

Pulsewidth modulated (PWM) solenoids form the basis of electronic pressure control within the modern electronic automatic transmission. PWM solenoids are able to vary pressure based on the output of the TCU. Many new transmissions use PWM shift solenoids to control the engagement and release pressures of the clutches and bands instead of the mechanical systems formerly employed. The TCU has up to nine PWM outputs which are provided for PWM devices. An important function of PWM outputs is PWM solenoid operation. Most transmissions require at least one PWM output to control line pressure for proper automatic transmission operation. Some transmissions will also require additional PWM outputs for accumulator pressure control or PWM shift solenoids. A PWM output is often required to smoothly lock and unlock the TCC. PWM outputs can also be driven at maximum duty cycle all of the time to perform like a digital output. However, you should only use a PWM output in this manner when all other digital outputs have been used.

PWM outputs control pulsed solenoids based on duty cycle (percentage of active time). PWM devices must operate at the appropriate frequency. The TCU offers a wide range of selectable frequencies, which you should use to plan the wiring of your PWM outputs. Select an output type of ground for devices that require a ground connection to activate. Select an output type of 12 volts for devices that require a power connection to activate. The operating frequency of the PWM solenoids in your transmission is not easily found in many cases. Please contact your dealer if you need further assistance with this parameter. Our online web forum is also a good location for installers and users to share information regarding specific applications and parameters like PWM frequency. For a complete list of PWM output options, please refer to chapter 3.

3.4.3 Speed Output

The TCU has one speed output to send a speed signal to the device of your choice. The most common application for this output is driving an electronic speedometer. You may choose to output driven or non-driven wheel speed. In some cases, it may be necessary to program a digital output to drive your speedometer. This happens with some GM applications that require a stronger signal to drive them properly. Only digital outputs 4, 5 or 6 may be used for this function.

3.5 Extra Features

The TCU has an immense level of flexibility, allowing the user to perform a vast number of functions beyond transmission control. The large number of extra inputs, outputs and datalogging capability form a package more powerful than many aftermarket engine controllers. The intended scope of control for the TCU seems limiting but we are certain users will find ingenious methods to push the TCU to its limits with functions unrelated to transmission control.

3.6 Communication

The TCU has been designed with RS232 and CAN 2.0b onboard. RS232 (Serial Communication) has been provided for communication with your computer. Though less convenient than USB, serial communication still offers the best reliability and capability in a noisy automotive environment. Our company has gone to great lengths to ensure reliable communication between your PC and the TCU. CAN 2.0b has been provided for communication with our other products as well as some other manufacturers products in the future. CAN 2.0b is a noise tolerant automotive communication network (Controller Area Network) that is the preferred modern communication standard.

If you do not have a serial port on your computer (some laptops do not) you may purchase a USB to serial port adapter and install the correct drivers before trying to communicate with the TCU. To ensure **compatibility and reliability**, please purchase our USB to serial adaptor which we have tested and sell at low cost.

3.7 TCU Location and Wire Routing

The TCU was designed with the rigors of the automotive environment in mind. The TCU is designed for a high temperature, caustic and humid environment. Though the TCU can easily live in such an environment, an installation location inside the vehicle is preferable. Please keep the TCU away from extreme heat sources, ignition wires or any obvious water sources.

Once you have chosen a location for your TCU, you may begin routing the wiring harness. Be careful to avoid moving parts and hot parts when routing the harness. Route the harness to your sensor locations and wire them as planned. Route the connectors and wires down towards the transmission. Watch for possible fitment issues or places where the harness can rub or be damaged over time.

3.7.1 General Wiring Hints

- **Neutral Safety circuit:** Some vehicles require that two wires are connected when the transmission is in park or neutral. The easiest way to deal with this provision is to install a relay and connect these two wires together. Then use a digital output from the transmission controller to trigger this relay when the transmission is in park or neutral. If you are unconcerned about a neutral safety switch you can simply wire these together and save yourself the complexity of a relay and using a digital output. This is not recommended however as the neutral safety switch exists for very good reasons. On some vehicles the neutral safety switch is housed in a connector that is also used for lever position determination. In these cases, the neutral safety and/or starter relay circuits should be wired into the vehicles harness.
- **Stock button shifting:** Some models come with button shifting as a feature on the stock vehicle. However, wiring a digital input from the TCU to the manual mode selection is sometimes not enough. Some vehicles use a separate “Shift ECU.” This requires power to use the button shifters. Therefore when in drive or manual mode, you will need to use a digital output from the TCU to trigger a relay to send power to the shift ECU when in manual mode or drive. In some applications this can also be remedied by splicing into the TCU

harness and restoring power from the lever selector to the appropriate wire from the transmission.

- Button shifting with add-on buttons or existing steering wheel features (often for cruise or stereo control): Some vehicles will use a single or multiple wires from the steering wheel to control your vehicle's stereo or cruise control. You can splice into this wire with a relay triggered by a switch to enter manual mode. Once triggered you will lose the original function of your steering wheel buttons but now have the ability to use these buttons for manual mode shifting. Many single wire systems use resistor banks to multiplex several button functions on one wire. This requires you to select the triggering voltage for the upshift and downshift buttons. To determine triggering voltages, an analog input must be used.

3.8 Final Steps

3.8.1 Find and wire necessary sensors

- You will need to find the wire locations for the sensors you wish to use. Every application requires a vehicle speed signal and should be installed with a load input. Typically this load input is a throttle position sensor (TPS). Vehicle speed can be measured at a driven wheel, a differential speed sensor or an output speed sensor on the transmission itself. RPM can be acquired from a distributor or ignitor tachometer wire. If you wish to use manifold absolute pressure (MAP) for load (boosted applications) or additional sensors, find them now.
- Refer to the wiring diagrams for your vehicle to determine the signal wires on each sensor. Please look at the wiring diagram on pg 62 & 63 to see what wires on the TCU are appropriate for your vehicle. If a custom harness is available for your transmission, use the wiring diagram for the custom harness instead.
- The method you use to tap into these sensors will depend on your experience and preference in connectors. For a permanent installation, please remember that no wire should be exposed to the elements. If possible, splice into your existing harness or wire in your own Y-harness. Always remember to use heat shrink, preferably the sealing or glue type of heat shrink, on any exposed wire joints or unsealed connections.

3.8.2 Wire power and ground connections

- Though simple this is an important step. Wire **switched** power to the TCU. On most applications, the power source should be protected with a 10amp fuse. Wire a ground connection to a clean ground terminal on the vehicle (preferably on the transmission or engine).

3.8.3 Install the TCU and route the wiring harness

- Place and secure the TCU in your chosen location and begin routing the wiring harness.
- Be careful to avoid moving parts and hot parts when routing the harness.
- Route the harness to your sensor locations and wire them as planned.

- Route the connectors and wires down towards the transmission. Watch for possible fitment issues or places where the harness can rub or be damaged over time.

3.8.4 Double check your installation

- Double check the installation of all connectors, splices and the routing of the harness for any potential fitment problems, hot spots or unprotected/exposed wires or connectors.

3.8.5 Communication

- A serial interface has been provided with the TCU. Though less convenient than USB, serial communication still offers the best reliability and capability in a noisy automotive environment. To communicate with the TCU, your computer must have a serial port. Many modern laptops do not have a serial port and you must purchase a USB to serial port adapter to be able to communicate with the TCU.
- To ensure **compatibility and reliability**, please purchase our USB to serial adaptor which we have tested and sell at low cost. Alternatively, we recommend the Iogear model GUC232A. These adapters are readily available and cost roughly \$20-30. Other USB to serial port adaptors may work (ex. Belkin model F5U409 or Keyspan model USA-19QW) but may be slow and unreliable and are therefore not recommended.

3.8.6 Start it up!

- Turn the key of the vehicle to the ignition position. Connect your PC to the TCU and start the TCU software. Verify communication between the TCU and your computer. The software will auto-detect the presence of the transmission controller. At this time you may hit ctrl-M to bring up the TCU monitor screen which will show you the current parameters of the TCU.
- You have now completed the installation process and are ready to tune the vehicle. For additional help with the software or the tuning process please refer to the full user manual that you received with your transmission controller or the quick tune guide. As a secondary resource a forum and support section have been made available at our website.

4. Chapter 2 – Software

4.1 Planning & Research

The first step in the proper tuning of the Automatic Transmission Controller (TCU) is to properly plan and execute your installation. You will need information from the installation process to properly program and tune the TCU for your transmission. If, for any reason, you were not involved in the installation process and are unaware of how the transmission was wired (with specific regard to inputs, outputs and their respective active states) you will need to refer to the full user manual. If a custom harness is available for your application, information should be provided for your transmission and how that harness is wired.

4.2 Background

Understanding and using computer software created for vehicle control can often be a difficult task even for the experienced. We have created a software package that mimics the user interface and menu system of common windows programs. Several navigation methods have been provided to allow you to choose the interface you prefer.

Fundamentally, software designed to control a device must include the options available for that device. The wealth of options offered by the TCU can make the software seem difficult or overwhelming at first because there are so many forms, settings and parameters. Please keep in mind that you **DO NOT** have to program every setting. There may be many options that you never need to use or learn. To tune a transmission, the user should understand how a transmission works but this is not fundamental in many cases.

Operation of an automatic transmission is relatively simple in principle. The transmission takes power from the engine and transmits that power to the driven wheels. The transmission shifts based on speed and desired acceleration. The shifts are actuated by changes in fluid flow which push on internal clutches or bands to engage different gears. The speed and force with which these clutches and bands are actuated depends on the pressure of the fluid going to them. Desired acceleration makes these shifts occur with more or less force depending on the user's choice. The torque converter acts as a torque multiplier as well as a device to smooth power transmission from the engine to the wheels.

Operation of a modern electronic automatic transmission is identical to this simplistic explanation where electronic control offers greater speed and control. When electronics are added to this transmission model, the possibilities expand greatly. With electronics you can control;

- Line pressure in every gear
- Shift speed for every gear based on desired acceleration and speed

- Shift firmness for every gear based on desired acceleration and speed
- The activation of the torque converter based on desired acceleration and speed

Controlling these parameters (pressure, shift speed, shift firmness and TCC activation) becomes a complex matter when you learn that they are often codependent functions.

For example, let's look at shift firmness. This parameter determines how hard the transmission shifts and is subjective in nature. What one user considers a hard shift may be considered a soft shift by another user. Shift firmness requires a user input for desired acceleration rate, engine speed, vehicle speed and current gear. Based on these inputs the TCU must calculate what shift firmness to deliver. Once calculated, the TCU must then implement this desired shift firmness. This is a difficult task because most transmissions behave in different ways and have differing levels of electronic control. The shift firmness may require controlling overall pressure, individual shift damper control, TCC state control and shift solenoid selection. Rather than provide a setting for shift firmness, the TCU provides tables and values for each of these inputs and outputs. Therefore to determine shift firmness at any time, all of the parameters for these inputs and outputs must be properly wired, configured and tuned. This method gives the user an immense level of control, equaling the sophistication of modern factory vehicles. To combat the complexity inherent in this system, we are constantly developing new wiring harnesses and instructions for specific transmissions. Most applications arrive with pre-programmed calibration specific to your transmission or a calibration can be easily obtained on our website.

4.3 Overview

This chapter will cover a detailed procedure and description for the tuning of a TCU in a generic application. Installation, communication, setup and tuning will be covered. The TCU software and hardware have been designed to be extremely flexible to incorporate both existing transmission and future transmission designs. As the software evolves, this manual will be updated accordingly and you may find that there are several revisions of both the TCU software and the TCU manual. For this reason, you may wish to check for both software and manual updates at our website. Most users will find many of the extra features of the TCU unnecessary for their needs.

4.4 Software Installation

A software CD is provided with every TCU purchase. If a software CD was not shipped with your purchase or if you need to purchase a replacement CD, please contact us. You may also download the newest revision of the software from our website. Once you have a software CD or a downloaded installation, you are ready to begin installing the TCU software.

Software CD installation: Load the software CD in your CD drive. A window should appear offering you several options, click "Install Software." If this menu does not appear, you will need to open your CD with windows explorer or my computer. You should see a file called TCU-CD.exe; double click this file to begin installation. An installation window

will appear with the TCU software version number, click next. A window will appear with your intended installation directory, we recommend not changing the default installation directory but you may choose any directory you wish. Once you have chosen a directory, click next. A window will appear offering to let you select installed components from a list. The software installation will only let you select/deselect manuals and optional components. Select the components you want to install and click next. A window will appear with your start menu folders. You may name the start menu folder associated with this software any name you wish, though we recommend the default setting. A window will appear offering to create a desktop icon and a quick launch icon. A desktop icon will place a shortcut to the TCU software on your user desktop. A quick launch icon will place a shortcut to the TCU software on the windows quick launch bar (only offered on some operating systems, usually on the lower left side of your screen next to the start menu button). Choose if you wish to install these icons and click next. A window will appear summarizing the settings you have chosen. If you approve of these settings, click install. If you disapprove of these settings, click back. After installation a window will appear asking if you wish to launch the TCU software now, make your choice and click finish.

Downloaded file installation: Find the location of the downloaded file from the website. If you cannot locate the file, you may need to search for the file which will be called TCU-CD.exe or TCU-WEB.exe depending on the version you downloaded. Double click on your downloaded file to begin installation. An installation window will appear with the TCU software version number, click next. A window will appear with your intended installation directory, we recommend not changing the default installation directory but you may choose any directory you wish. Once you have chosen a directory, click next. A window will appear with your start menu folders. You may name the start menu folder associated with this software any name you wish, though we recommend the default setting. A window will appear offering to create a desktop icon and a quick launch icon. A desktop icon will place a shortcut to the TCU software on your user desktop. A quick launch icon will place a shortcut to the TCU software on the windows quick launch bar (only offered on some operating systems, usually on the lower left side of your screen next to the start menu button). Choose if you wish to install these icons and click next. A window will appear summarizing the settings you have chosen. If you approve of these settings, click install. If you disapprove of these settings, click back. After installation a window will appear asking if you wish to launch the TCU software now, make your choice and click finish.

4.5 Communication

The TCU has been designed with RS232 and CAN 2.0b onboard. RS232 (Serial Communication) has been provided for communication with your computer. Though less convenient than USB, serial communication still offers the best reliability and capability in a noisy automotive environment. Our company has gone to great lengths to ensure reliable communication between your PC and the TCU. CAN 2.0b has been provided for communication with our other products as well as some other manufacturers products in the future. CAN 2.0b is a noise tolerant automotive communication network (Controller Area Network) that is the preferred modern communication standard.

If you do not have a serial port on your computer (some laptops do not) you may purchase a USB to serial port adapter and install the correct drivers before trying to communicate with the TCU. To ensure **compatibility and reliability**, please purchase our USB to serial adaptor which we have tested and sell at low cost.

Communication can be started with the TCU in several ways. If you connect your computer to the TCU and start the TCU software, the software will attempt to auto-detect the presence of your TCU. If the TCU software is unable to auto detect the presence of the TCU, you should double check that your serial port is active or your USB to serial port adapter is properly installed and functioning. Once your hardware has been checked, use the Communications -> Go Online command to attempt to connect to the TCU again. If you are still unable to connect to the TCU, please contact our technical support.

4.6 File Management

When you go online or you auto-detect the TCU, the software will ask you if you wish to retrieve the TCU calibration from the unit. If you choose to do this, you will be loading your settings from the TCU and will then be online with the TCU. **If you make changes at this time, those changes will be immediately reflected in the unit.** You should always save your program somewhere on your computer. Also remember to use an adequately descriptive name such as 1993-Firebird-350Ramjet-4L65E-1-13-04.TCU if you are a reseller/tuner or perhaps just 1-13-04.TCU if you use the TCU on a single vehicle.

You may select offline mode or simply work without a TCU connected to your computer. When you are in offline mode, you can make changes to any program on your computer. You can open calibrations by choosing the open icon on your toolbar or by choosing File-> Open calibration file. You can save these files with any file name and in any directory you choose. Remember that when you are offline, you must save your file for changes to be reflected in that calibration.

4.7 Software Walkthrough

4.7.1 Working with calibration files

A calibration file stores the information required to control the TCU for each application. Calibration files can differ greatly between applications and should be managed with care. When using the TCU for the first time, your TCU should have a calibration installed to match your specific transmission. If a calibration has not been loaded specifically for your transmission, then you will need to contact your reseller or find an appropriate calibration.

4.7.2 Online Mode vs. Offline Mode

When in offline mode, the software background will be gray. Offline mode simply means that the TCU is not connected and is not currently communicating with the PC. Any changes made to a calibration while in offline mode must be saved in that calibration and will not affect the TCU unless that calibration is sent to the TCU when it is connected.

When in online mode, the software background will be blue. Online mode simply means that the TCU is connected and is currently communicating with the PC. Any changes made to the calibration will occur in real-time and will directly affect the programming of the TCU.

4.7.3 Transmission Setup

1. **Verify Communication.** The TCU software will attempt to auto-detect the TCU when it is plugged into your computer. If the TCU software is unable to auto detect the presence of the TCU, you should double check that your serial port is active or your USB to serial port adapter is properly installed and functioning. Check that no other software is running and that no other programs may be using the serial port. Often customers will have PDA software, GPS software or a second session of the TCU software running which will interfere with proper TCU communication. Once your hardware has been checked, use the Communications -> Go Online command or CTRL-G to attempt to connect to the TCU again. If you are still unable to connect to the TCU, please contact our technical support.
2. **Open Calibration.** You will need to load a calibration from your TCU (if connected), start a new file or open an existing file. You can open calibrations by choosing the open icon on your toolbar or by choosing File-> Open calibration file. You can save these files with any file name and in any directory you choose. Remember that when you are offline, you must save your file for changes to be reflected in that calibration.
3. **Transmission Setup.** Before tuning your calibration, you should verify that your controller has been setup properly. The transmission setup will step through all of your inputs, outputs and solenoid logic. **Severe damage may occur** if the transmission setup section has not been programmed properly for your transmission.
4. **Analog Inputs.**
 - 4.1. The TCU has six analog inputs which read a 0-5v scaled input. Analog inputs are important for a variety of sensors such as throttle position (TPS), Manifold Absolute Pressure (MAP), Engine Coolant Temperature (CLT) and Transmission Fluid Temperature (TFT). An analog input can also be used with stock steering wheel buttons, like cruise control and volume control, of some vehicles where different buttons correspond to different voltages. An example wiring layout is shown on page 47 & 48. These voltages can be programmed to perform upshifting and downshifting when in manual mode.
 - 4.2. Analog inputs 1-4 have been designed so that they can piggyback any sensor from an engine controller or directly measure most sensors. Analog inputs 1-4 should not be used to directly measure any temperature sensors or other resistance based 2-wire sensors. Analog inputs 5-6 have been designed so that they can measure any sensor directly. Analog inputs 5-6 should not be used to piggyback any sensors from an engine controller. Analog inputs 5-6 should be used to directly measure any temperature sensors or other resistance based 2-wire sensors. The proper use for analog inputs 1-6 are visually represented in *Table 4*. For a complete list of analog input options, please refer to the full user manual.

Table 4. Analog Input Matrix.

	Analog Inputs					
	1	2	3	4	5	6
Use to piggyback any sensor from engine controller.	•	•	•	•		
Use to measure any sensor directly except temperature sensor or other resistance based 2-wire sensors.	•	•	•	•		
Use to measure any sensor directly.					•	•
Use to measure temperature sensors or other resistance based 2-wire sensors directly.					•	•

4.3. A typical application example is a GM 4L60E. In this case, the throttle position sensor (TPS) is used as analog input 1. The TPS function values are determined by looking at the TCU software monitor screen when the throttle is closed and when it is open to determine the closed throttle and open throttle voltages respectively. The manifold absolute pressure (MAP) sensor is used as analog input 2. The engine coolant temperature sensor (CLT) is used as analog input 3 because it is piggybacked from an engine controller. The transmission temperature sensor is used as analog input 6 because it is a directly measured temperature sensor.

4.4. Some sensors require a complete voltage vs. parameter (PSI, temp, MPH, etc) curve to be programmed in the analog input function form. For these cases, some calculation may be required to obtain 16 points. In some cases, this will be complicated by a pull-up resistor on the OEM ECU or by a pull-up resistor on the TCU. To help with this calculation, use the Wizards -> Sensor Calibration Wizard tool in the software.

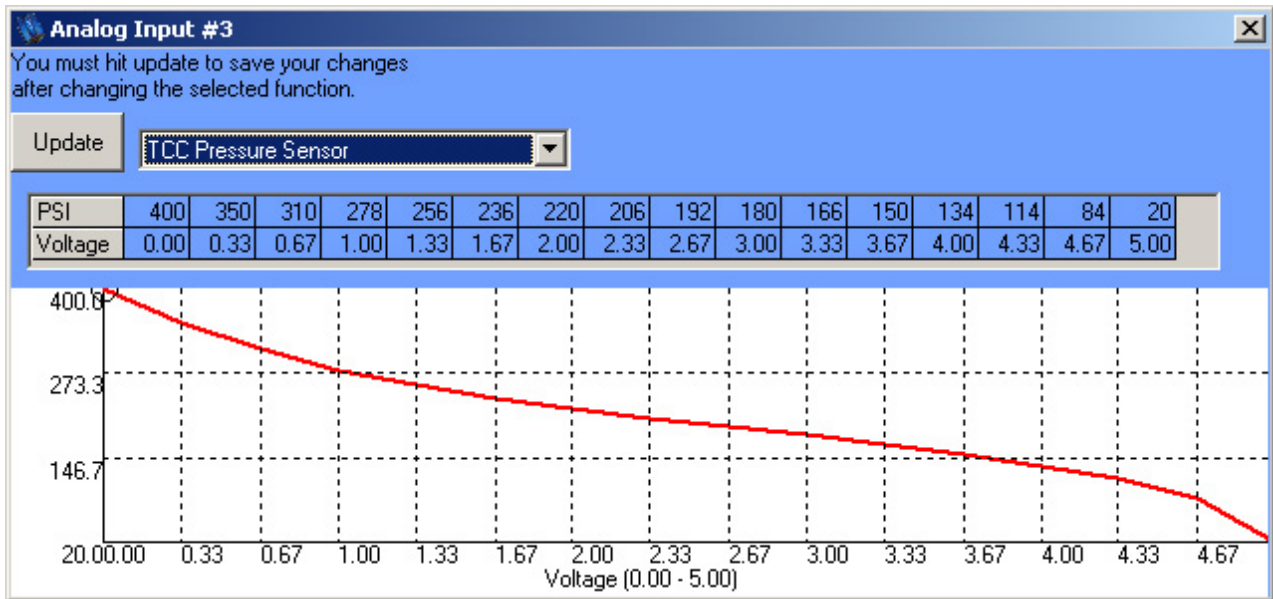

Figure 8. Analog Input Graph.

- 4.5. Failure values are provided for each analog input. These should be used to determine a short or problem with each analog input. A default failure value is also provided for limp-home operation in the case of analog input failure. If the measured voltage for this analog input falls below the failure low value or above the failure high value, a failure will be triggered and the TCU will default this analog input to the voltage to assume upon fail value.
5. Breakpoints and Configuration. The breakpoints and configuration table provides a central location to determine the scale of several graphs, load determination for several parameters and sensors used for temperature trims. It is usually only necessary to alter these values in highly modified applications or high boost vehicles.
6. Digital Inputs.
 - 6.1. The TCU has sixteen digital inputs which are provided for simple on/off devices. An important function of digital inputs is gear selection. Most transmissions require several digital inputs be wired to the transmission or lever position switch to determine which gear the driver has selected. A brake light input is another important use of a digital input. When activated, this input will unlock the torque converter (TCC). Additional on/off inputs may include buttons for mode switching (performance mode, tow mode, manual mode, etc).
 - 6.2. Each digital input has five parameters to consider: Function, active high or active low, button type (momentary or toggle), and reverse logic. This programmability allows the user to wire the digital inputs in almost any configuration or with almost any type of switch and still function properly. Select active high for inputs that are on when power is applied. Select active low for inputs that are on when ground is applied. Select momentary for buttons that are depressed for a short time period before returning to their original state. Select toggle for buttons that are depressed or moved and stay in their position until moved again. Select reverse logic for buttons or switches that are active when neither power nor ground is applied and inactive when power or ground is applied. For a complete list of digital input options, please refer to chapter 3.
 - 6.3. To use manual mode shifting, a digital input must be programmed for manual mode and must be active. Once activated, digital inputs or analog inputs may be configured for upshifting and downshifting. Test mode is also available in the communications drop-down. Test mode will allow the software to control manual mode operation, calibration B, tcc lockup, upshifts, downshifts and more.
7. Frequency Range Switch. This is a special control only used for a small number of transmissions (ex. 5R110 Torqshift). Do not enable this feature unless you are certain you have a transmission with a FREQUENCY based range switch.
8. Gear Select/Solenoid Output. This chart is complex because it integrates the entire shift logic of your transmission. You will need to select the number of gears you have. You will also need to input your gear selection input and corresponding solenoid output logic. If you are confused about how to properly deal with these settings, it is best to contact our technical support. Setting the gear select inputs and solenoid outputs improperly may result in **severe damage** to your transmission.

8.1. Advanced Solenoid Output. This chart is only for advanced users. This chart serves several purposes. This first is to allow timed solenoid overlap for transmissions require this type of control. If your transmission does not require this type of control (most don't), do not enable this feature. On the right side of this form is a Shift Period for each shift. The shift period can be important for overlap and it can also be important for PWM shift solenoids. The shift period must be longer than the time it normally takes to complete a PWM shift event (as programmed in the PWM outputs section). If the shift period is shorter than the PWM shift event, then the PWM shift event may not complete its cycle correctly.

9. PWM Outputs.

9.1. PWM Frequency Selection. PWM devices should operate at the appropriate frequency. The TCU offers a wide range of selectable frequencies but not all frequencies are available on all outputs. Therefore you should plan the wiring of your PWM outputs based on these frequency selections. Avoid using PWM outputs 7, 8 & 9 at high frequencies. Always use PWM outputs 1 through 6 before using PWM 7, 8 & 9.

9.2. Pulsewidth modulated (PWM) solenoids form the basis of electronic pressure control within the modern electronic automatic transmission. PWM solenoids are able to vary pressure based on the output of the TCU. Many new transmissions use PWM shift solenoids to control the engagement and release pressures of the clutches and bands instead of the mechanical systems formerly employed. The TCU has up to nine PWM outputs which are provided for PWM devices. An important function of PWM outputs is PWM solenoid operation. Most transmissions require at least one PWM output to control line pressure for proper automatic transmission operation. Some transmissions will also require additional PWM outputs for accumulator pressure control or PWM shift solenoids. A PWM output is often required to smoothly lock and unlock the TCC. PWM outputs can also be driven at maximum duty cycle all of the time to perform like a digital output. However, you should only use a PWM output in this manner when all other digital outputs have been used and the PWM should be programmed for a very low frequency.

9.3. PWM outputs control pulsed solenoids based on duty cycle (percentage of active time). PWM devices must operate at the appropriate frequency. The TCU offers a wide range of selectable frequencies, which you should use to plan the wiring of your PWM outputs. Select an output type of ground for devices that require a ground connection to activate. Select an output type of 12 volts for devices that require a power connection to activate. The operating frequency of the PWM solenoids in your transmission is not easily found in many cases. Please contact your dealer if you need further assistance with this parameter. Our online web forum is also a good location for installers and users to share information regarding specific applications and parameters like PWM frequency. For a complete list of PWM output options, please refer to chapter 3.

10. Digital Outputs.

10.1. The TCU has six digital outputs which are provided for simple on/off devices. The first three digital outputs may also be configured as PWM Outputs. The most important function of digital outputs is shift solenoid operation. Several PWM or digital outputs are typically wired to the transmission to actuate the shift solenoids for proper

automatic transmission operation. Some transmissions also require a digital output for Torque Converter Clutch (TCC) actuation. Digital outputs may be used to light indicators for manual mode, snow mode, TCC lock/unlock, calibration B, etc. Typically the first several digital outputs are used for shift solenoids in the transmission.

- 10.2. Each digital output has two parameters to consider: Function and active high or active low. This programmability allows the user to wire the digital outputs in almost any configuration or with almost any type of digital device and still function properly. Select the digital output function based on what you want this digital output to do. Select an output type of ground for devices that require a ground connection to activate. Select an output type of 12 volts for devices that require a power connection to activate. For a complete list of digital output options, please refer to chapter 3.

Table 5. Speed Input Matrix.

	Directly measurable	Can be Calculated	Parameters for direct measurement	Parameters for calculation
Engine RPM	•		# of Cylinders	NA
TCC Speed	•	•	# of teeth	Gear Ratios Driveshaft Speed
Driveshaft Speed	•		# of teeth	NA
Driven Wheel Speed	•	•	#of teeth	Driveshaft Speed Final Drive Tire Diameter
Non-Driven Wheel Speed	•		#of teeth	NA

11. Speed Inputs/Gearing Chart. The only **required** speed input is driven wheel speed.

- 11.1. Engine RPM must be directly calculated and you must input the number of cylinders to receive the correct RPM value.
- 11.2. Torque converter RPM can be directly measured directly on some transmissions and you must enter the number of pulses per revolution to receive the correct RPM value. Most applications can simply choose a calculated torque converter RPM value which does not require a value for the number of pulses per revolution but does require driveshaft speed and the correct gear ratios for your transmission.
- 11.3. Driveshaft RPM must be directly measured and you must enter the number of pulses per revolution.
- 11.4. Driven wheel speed can be calculated only if you have driveshaft RPM, driven tire diameter and final drive ratio. Driven wheel speed can also be measured directly and you must enter the number of pulses per mile for proper TCU function.
- 11.5. Non-driven wheel speed can only be measured directly and you must enter the number of pulses per revolution for non-driven speed to display correctly.

- 11.6. A speed output is programmable from this form. You may choose to output driven or non-driven wheel speed and you must enter the pulses per mile (which depends on the device you are driving).
- 11.7. A gearing calculation section has been added to this form which will calculate your maximum speed in each gear based on your gear ratios, final drive ratio, tire size and desired shift/max RPM. If you wish to see different values for different RPM points simply change the RPM value to perform the calculation again, this is only provided for the purpose of calculation.
- 11.8. If you do not know your tire size, a tire size calculator is available by clicking the help button on this form.

12. Trigger Levels & Filter Values.

- 12.1. Trigger levels are provided for each speed input. This value is provided because different sensors provide different signals. Setting a Trigger value too low may cause the speed input to be triggered by electrical noise in your vehicle. This is most readily observed by excessive triggering, false triggering and/or a datalog graph that shows little consistency. Setting a Trigger value too high may cause the speed input to remain untriggered by the sensor input. This is most readily observed by no triggering and/or a datalog graph that shows no change.

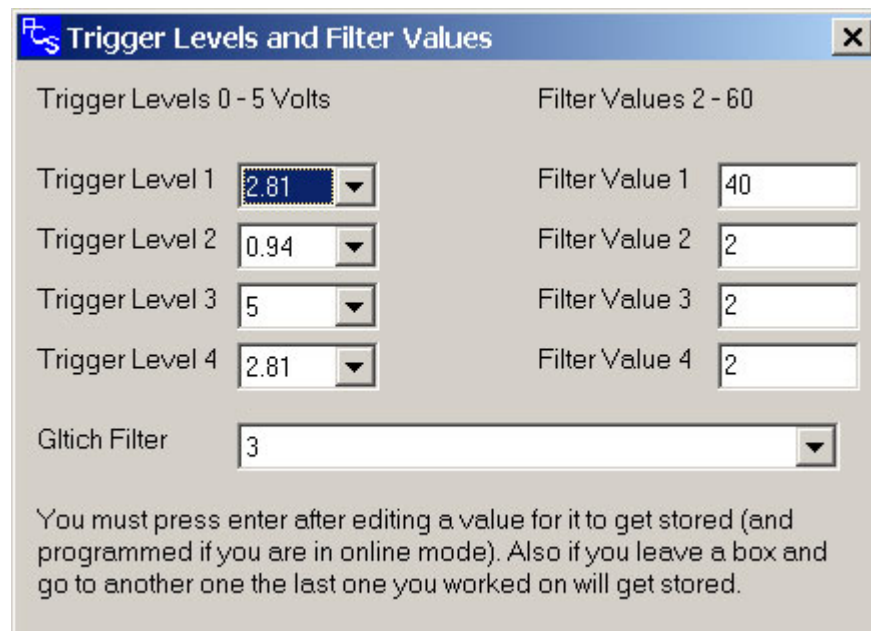

Trigger Levels 0 - 5 Volts		Filter Values 2 - 60	
Trigger Level 1	2.81	Filter Value 1	40
Trigger Level 2	0.94	Filter Value 2	2
Trigger Level 3	5	Filter Value 3	2
Trigger Level 4	2.81	Filter Value 4	2
Glitch Filter		3	

You must press enter after editing a value for it to get stored (and programmed if you are in online mode). Also if you leave a box and go to another one the last one you worked on will get stored.

Figure 9. Trigger Levels and Filter Values

- 12.2. In *Figure 9* RPM is set as trigger level 1 and VSS is set as trigger level 2. The RPM input on this vehicle is very noisy and provides a relatively high voltage signal. Therefore the trigger level is set relatively high and the filter is set very high. The VSS input on this vehicle is less noisy and we would like it to start reading correctly at a

relatively low vehicle speed. To accomplish this, the trigger level is set relatively low and the filter is set relatively low.

- 12.3. Filter values are provided to eliminate noise and change the cutoff frequency of the filter. Increasing the filter value lowers the cutoff frequency on this lowpass filter. This has an effect on the ability of the TCU to display a high frequency input. For an engine RPM input (low frequency) you will want to set the filter to something between 30 and 60. For a vehicle speed input (high frequency) you will want to set the filter to something between 2 to 10. Setting a filter value too high may cause a speed input to stop reading at high speed/RPM because it will be clipped at a higher frequency.
- 12.4. Glitch filter values are provided as added logic to ensure proper speed input values. The glitch filter works by checking the speed input trigger signal to see how long it has remained at or above the trigger level. The trigger level has to stay high for a particular time period before being detected as a valid edge. A higher glitch filter setting is a longer edge detection time period. We recommend a glitch filter setting of 3 (maximum). This procedure ensures that erroneously high or low values will not be considered valid by the TCU.
- 12.5. These values only need to be adjusted in cases where your speed inputs are not working properly. An example is a speedometer that is reading erratically or will only start working at an above normal mph. Trigger values can be adjusted such that the corresponding speed input reads correctly at low speed/RPM. Trigger values can be lowered if your speed inputs are not triggering or are triggering only at high speeds. Filter values can be raised if you are experiencing significant speed input scatter.
- 12.6. Proper driveshaft speed detection should occur at approximately 2mph. Proper wheel speed detection should occur at approximately 4mph. Proper RPM detection should occur at approximately 100 RPM.
- 12.7. If you are having a problem with the trigger level and filter value settings, please visit our website or contact technical support. Our website offers direct support and you may find other users who have already found the correct settings for your vehicle/transmission and will provide a reference for future users.

4.7.5 Calibration/Tuning

1. This section will walk through the basics of tuning an electronic automatic transmission. First verify that the transmission setup has been correctly programmed for your transmission.
2. Load vs. Accumulator Pressure. Many modern transmissions do not use an electronic accumulator and this form can be skipped unless your transmission uses an electronic accumulator. Typically accumulator pressure is a function of line pressure but offers additional control over shift speed and firmness. The accumulator can be thought of as a type of fluid damper. Without accumulators, shifting would feel much like “dropping” the clutch in a manual transmission. Many electronic transmissions do not offer electronic control of the accumulators. The greater the duty cycle applied to this solenoid, the lower accumulator pressure for most transmissions. Less accumulator pressure generally translates into quicker shift speeds and firmer shifts. In most configurations you will also want to use load (TPS or MAP) as an indicator of desired shift speed and firmness. At higher load you will want greater shift aggressiveness and at lower load you will want less shift

aggressiveness. In most configurations you will want the most aggressive shifting speed and firmness in higher gears and less aggressive shifting speed and firmness in lower gears (to reduce drivetrain shock and increase driver comfort). This is graphed as Load (TPS or MAP) vs. Duty Cycle.

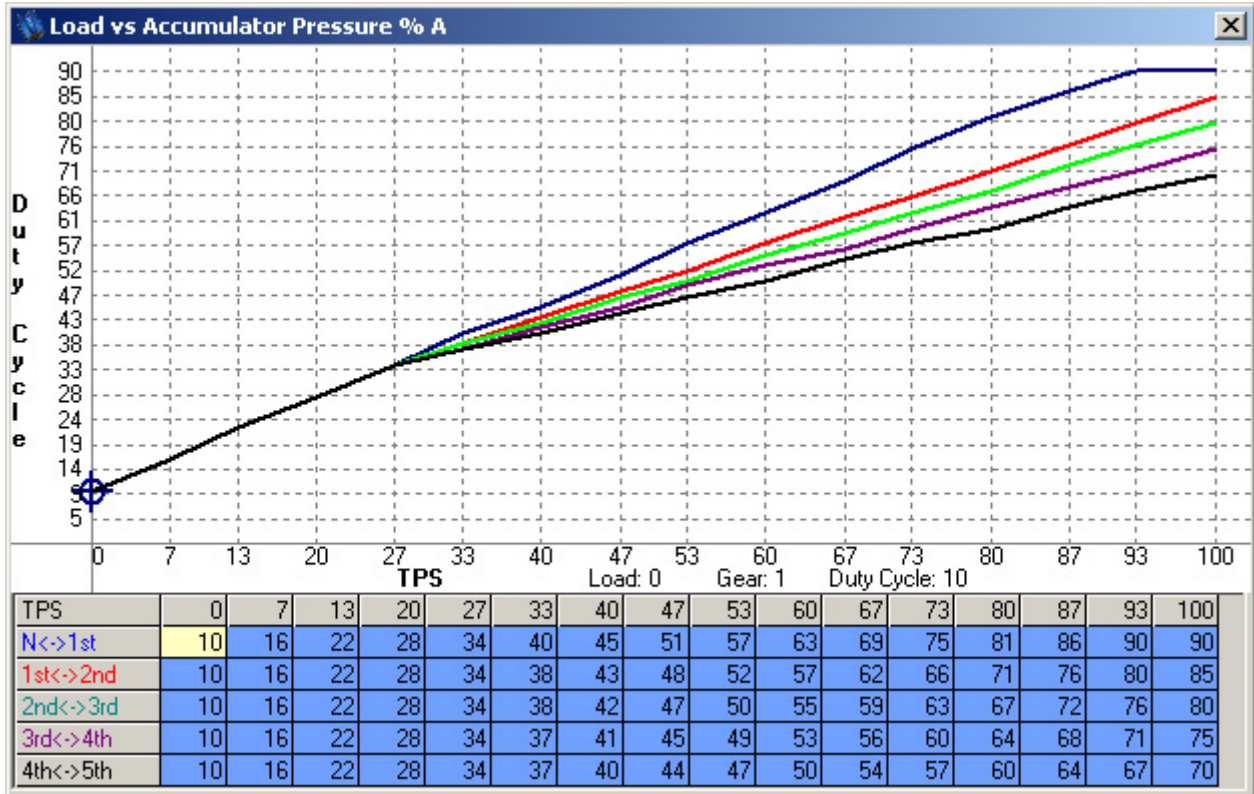

Figure 10. Load vs. Accumulator Pressure (duty cycle)

3. Load vs. Line Pressure. The line pressure solenoid is a bypass device. The greater the duty cycle applied to this solenoid, the lower the line pressure for most transmissions. Lower line pressure generally translates into slower and softer shifts and lower clutch/band holding force. Higher line pressure generally translates into quicker shift speeds and firmer shifts and higher clutch/band holding force. In most configurations you will want to use load (TPS or MAP) as an indicator of desired shift aggressiveness. At higher load you will want greater shift speed and firmness and at lower engine load you will want lower shift speed and firmness. In most configurations you will want the most aggressive shifting speed and firmness in higher gears and less aggressive shifting speed and firmness in lower gears (to reduce drivetrain shock and increase driver comfort). This is graphed as Load (TPS or MAP) vs. Duty Cycle.

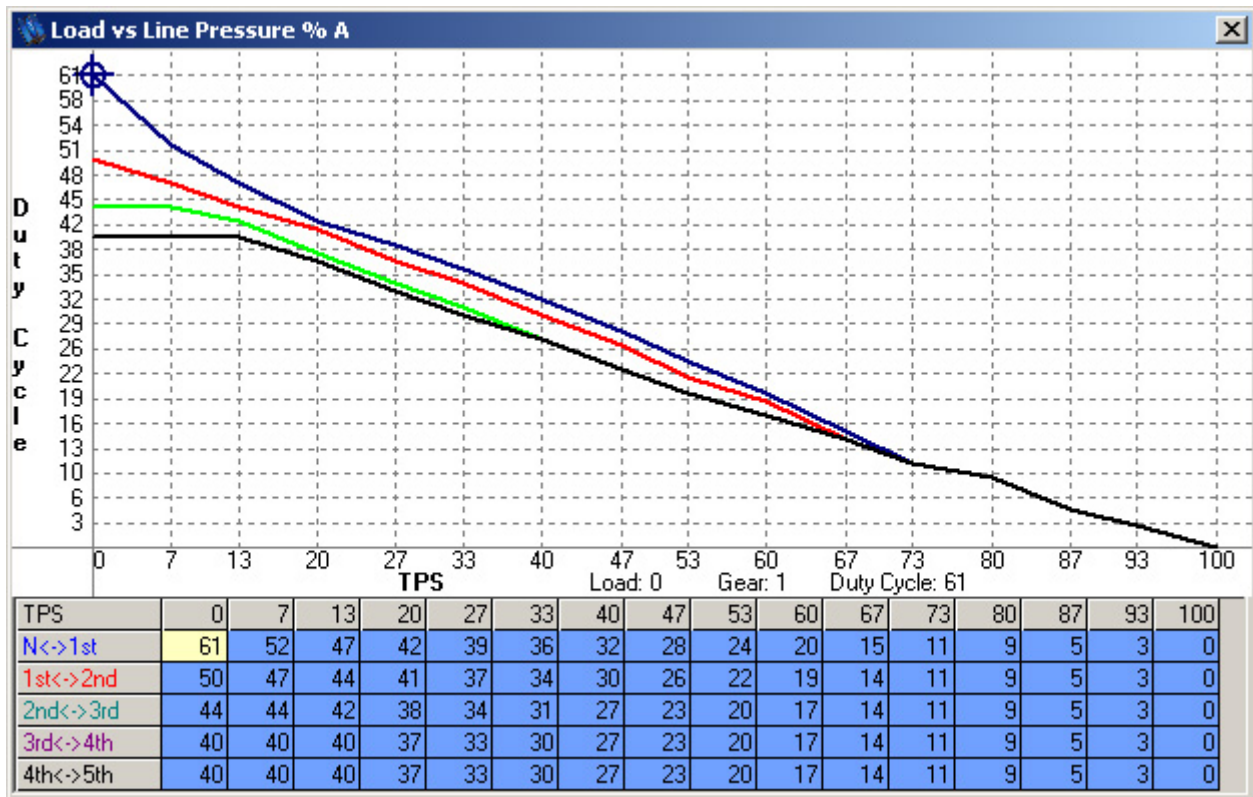

Figure 11. Load vs. Line Pressure (duty cycle)

4. Upshift/Downshift Tables. The tables that control part throttle upshift and downshift parameters have been broken down by gear. We have chosen to group the upshift to the next gear and the downshift to the prior gear on the same form to prevent shift table overlapping which could inadvertently trap the transmission in the wrong gear or cause gear hunting and unnecessary shifts. For advanced users a table is available showing all upshifts and downshifts as well as current state in a single form. Keep in mind while editing this table that the WOT settings contain your full throttle upshift and downshift parameters and should be matched to these tables. Also keep in mind that your TPS input must be configured to determine what WOT throttle is.

4.1. Low gear to high gear shift (upshift). A good example to walk through is pictured in Figure 12. The shift table below shows a 1st to 2nd gear shift with a blue line. In most configurations you will want to use load (TPS or MAP) as an indicator of desired shift speed. At low load you will want a low shift speed to keep the engine from revving too high. Maintaining a low shift speed will also lead to smoother shifting as line and accumulator pressure are typically programmed for softer operation at low load. At high load you will want a high shift speed to utilize full engine power before shifting. Your upshift points (blue line) should always be higher than your downshift points (red line). In each cell, the transmission will not upshift until reaching the speed value in the box for each load point. Be careful not to exceed your maximum RPM with any speed value. The speed input/output form has a speed calculator based on engine RPM, gearing, final drive ratio, and tire size which can help you match this chart to your WOT settings.

4.2. High gear to low gear shift (downshift). *Figure 12.* provides a good example of a 2nd to 1st gearshift. Similar methodology applies to the downshift as did for the upshift in this form. In each cell, the transmission will not downshift until reaching the speed value in the box for each load value. Be careful not to exceed your maximum RPM with any speed value. The speed input/output form has a speed calculator based on engine RPM, gearing, final drive ratio, and tire size which can help you match this chart to your WOT settings. Always keep adequate room between the upshift table and downshift table. If you do not, your transmission may hunt for gears and shift too often or in inappropriate situations.

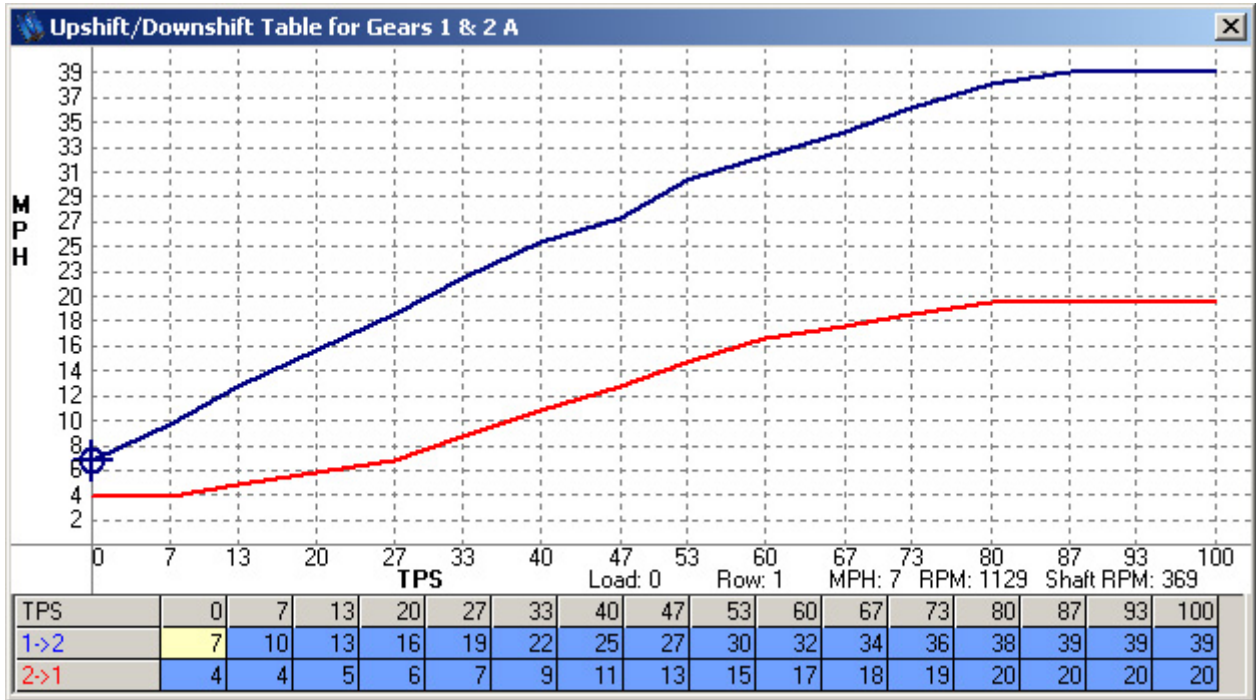

Figure 12. Upshift/Downshift Table

4.3. TCC lockup per gear. Some advanced users need the ability to tune torque converter lockup parameters in every gear. This can significantly complicate the upshift/downshift forms and this feature should only be used by advanced users and for installations requiring this complexity. Once enabled, this feature gives the installer the ability to alter the TCC lockup and unlock points in each upshift/downshift table based on speed and load, see *Figure 13.*

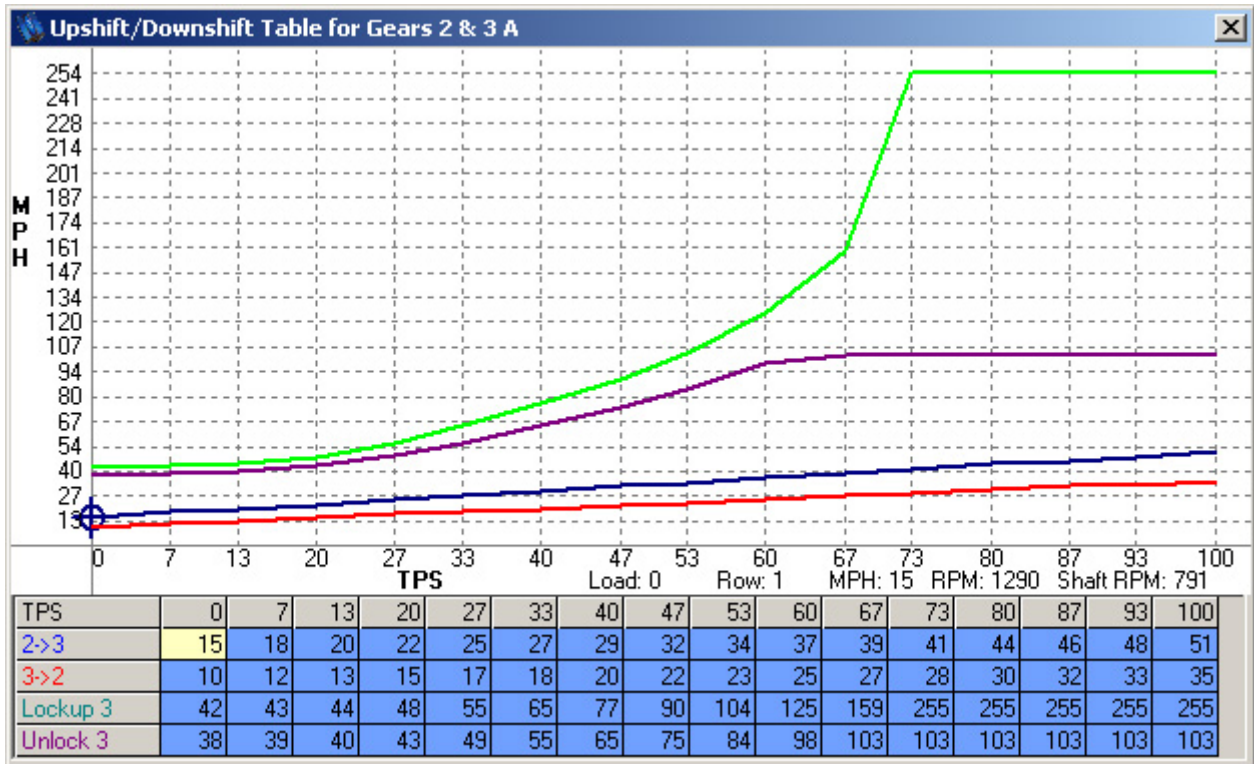

Figure 13. Upshift/Downshift Table when TCC lockup per gear is enabled

5. PWM TCC Pressure Control. Torque converter lockup rate control is provided to allow for smooth lockup and unlocking of the torque converter. This does not often need to be changed from the default settings unless you wish to change the TCC lock/unlock behavior (quicker, slower or change its firmness). Be sure to set the lockup ending duty cycle at a value that is high enough to prevent TCC slippage when the converter is locked!

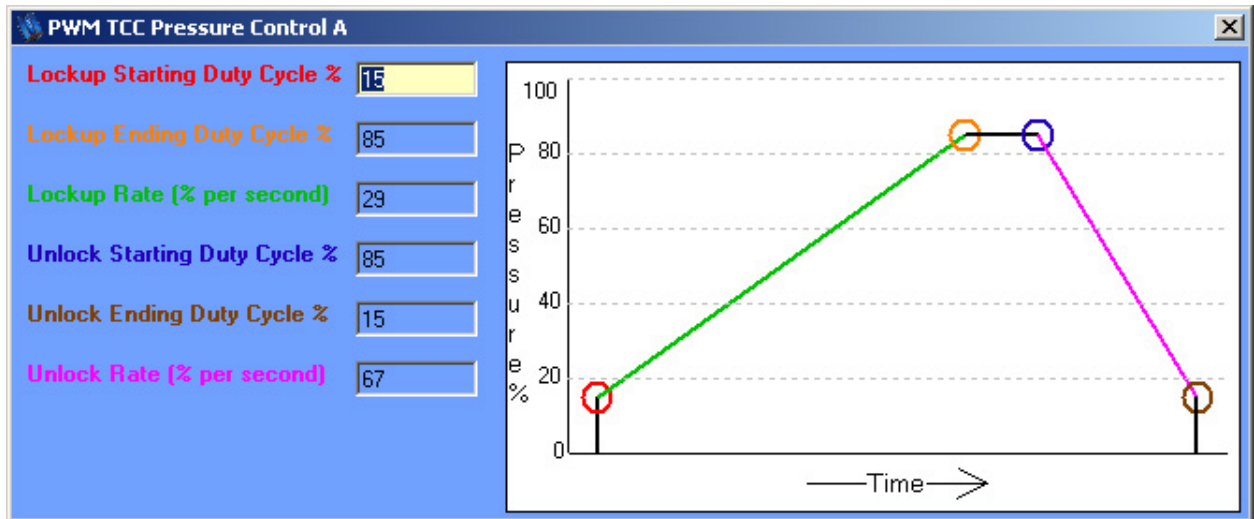

Figure 14. PWM TCC Pressure Control Table

6. TCC Lockup Parameters. Enter the first gear to begin locking up the torque converter clutch (TCC) in (some transmissions will not allow lockup in some gears, usually 1st gear). Preventing lockup when the engine and transmission is cold helps to warm your engine and transmission more rapidly in cold conditions. At high fluid temps the torque converter can be locked to prevent the thermal breakdown of your transmission fluid, seals and mechanical failure. TCC lockup may be selected per gear or for all gears (normal). TCC lockup per gear provides a different TCC lockup and unlock curve for each gear. Normal TCC lockup provides a single TCC lockup and unlock curve that is not gear related. Most users should select normal TCC lockup. TCC lockup per gear should only be used by advanced users and for installations requiring this complexity. The TCC can be unlocked during upshifts and downshifts to provide smoother shifting and alleviate drivetrain harshness.

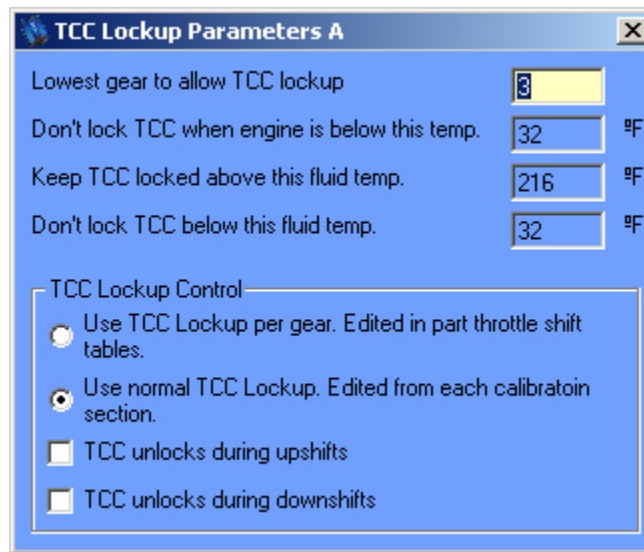

Figure 15. TCC Lockup Parameters

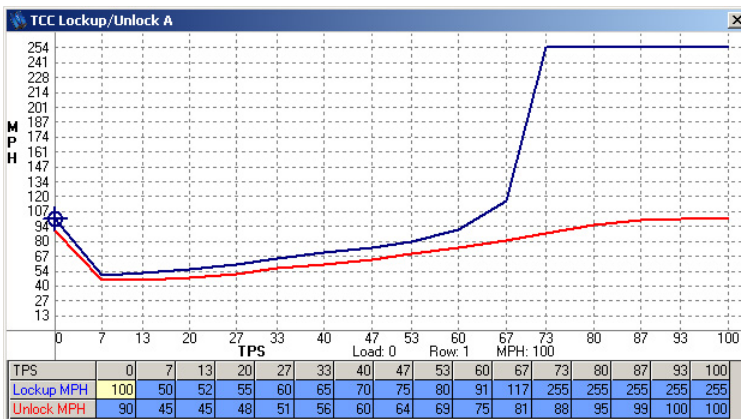

Figure 16. TCC. Lockup with quick throttle response

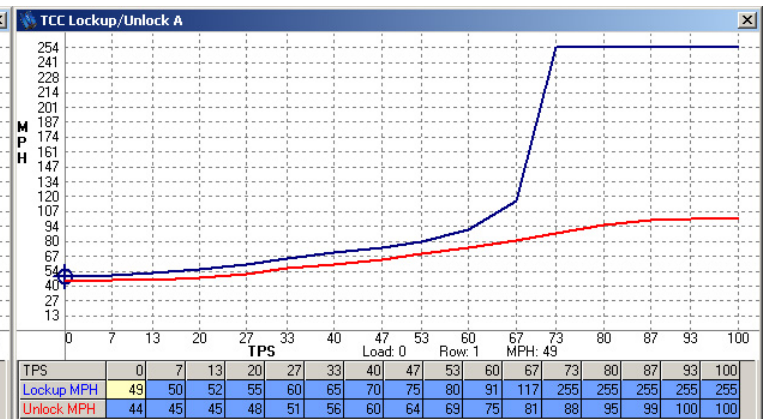

Figure 17. Normal TCC lockup curve.

7. TCC Lockup/Unlock. This table allows the user to define at what speed and load the torque converter will lock or unlock. One trick some users choose is to raise the lockup MPH at zero throttle. This is only useful when you need quick acceleration from a closed throttle

condition. An example follows; if you are towing and coming down a hill, you may be at zero throttle. When you start going up the next hill, setting your lockup this way will keep the converter from locking up thereby providing quicker throttle response. An example graph can be seen in *Figure 16*. Most applications will want to use a normal TCC lockup curve as found in OEM applications. An example of a normal TCC lockup curve can be seen in *Figure 17*. If TCC lockup per gear has been selected, the TCC lockup and unlock curves will be in the upshift/downshift tables and the TCC Lockup/Unlock table will disappear.

8. Temperature Tables. Two temperature tables have been provided to assist in extreme temperature conditions.
 - 8.1. A Temperature vs. line pressure trim allows the user to raise or lower the line pressure in extreme climates. This trim can be based on the engine coolant temperature sensor or transmission fluid temperature sensor. The default will be the transmission temperature sensor because the behavior of line pressure with respect to temperature should be based on the transmission fluid temperature.
 - 8.2. A Temperature vs. Upshift/Downshift point trim allows the user to raise or lower the shift points in extreme climates. This allows the engine to warm up at an accelerated rate in cold conditions. This trim function also allows the user to lower the shift points when the engine & transmission are overheating. This trim can be based on the engine coolant temperature sensor or transmission fluid temperature sensor. The default will be the engine coolant temperature sensor because this feature allows accelerated warm up for the engine in cold conditions.
9. Vehicle Slip Parameters. The vehicle slip table allows a tuner to prohibit upshifting or downshifting during slip conditions (while one or more wheels are spinning excessively due to poor traction). This feature is especially useful to prevent a vehicle from upshifting through several gears because of a false rise in vehicle speed (when the driven wheels are slipping). This feature can also be useful to prevent downshifting during wheel lockup. Set the percentages to values appropriate for your application based on speed. Set the Disable Up% to 100% to prevent upshift disabling based on wheel slip conditions. Set the Disable Down% to -100% to prevent downshift disabling based on wheel slip conditions.
10. Wide Open Throttle (WOT) Settings. These parameters determine where your vehicle will upshift and downshift when the Throttle Position Sensor (TPS) reaches a value high enough to trigger WOT mode. You can define what WOT is by changing the WOT voltage in the analog input for your TPS. To disable the WOT mode altogether, program 0% for the % of WOT throttle voltage to use WOT parameters in the TPS analog input form. The WOT upshift rpm values determine when your transmission will upshift with respect to engine RPM. This is programmable per gear, so the WOT upshift RPM for 1st gear controls the 1-2 upshift RPM. WOT downshifts are determined by speed and determine the minimum speed at which the next lower gear may be selected. For example if you are in 4th gear and go WOT at 95mph, you will only downshift to 3rd if you place a value greater than 95mph in the WOT downshift MPH 4th gear setting. When setting these parameters please keep your engine RPM in mind. You should never allow a WOT downshift near redline because you will be immediately upshifting or over-revving. Your WOT values should be matched to your part throttle upshift and downshift tables. The Speed input/output chart has a calculator to correlate engine RPM and vehicle speed in each gear based on the parameters you enter.

This should help you make the correlation between a particular WOT upshift RPM value and a speed in your upshift/downshift tables if needed.

11. Calibration B. Calibration B provides a completely different calibration which allows different accumulator pressure, line pressure, shift points, tcc lockup points, tcc pressure control, tcc lockup parameters, temperature trims, vehicle slip parameters and WOT settings. Calibration B can be used to provide a completely different driving experience (ex. Towing mode, economy mode, racing mode). To enable calibration B, a digital input must be set to trigger calibration B or test mode may be used to trigger calibration B. Some users link manual mode operation with calibration B so that when a manual mode input is triggered, a calibration B input is also triggered. This provides different line pressure, tcc lockup and trim parameters for manual mode shifting.
12. Copy Calibration. This form has been provided to speed tuning of calibration B. Choose which calibration to copy from and which to copy to. This will overwrite the previous calibration being copied to.
13. Dyno Mode. Dyno mode is provided to allow use on a chassis dynamometer without any upshifts or downshifts. Once the programmed gear and speed are reached, the TCC will remain engaged until the vehicle speed becomes low enough to trigger a downshift at the 0% load/throttle value in the part throttle upshift/downshift tables.
14. PWM Shift Solenoid Slope Period. The slope period as defined in this table is highly specific and should only be enabled by advanced users. This feature only affects PWM shift solenoids and specifically the 3rd slope time as defined by the PWM shift solenoid parameters in the Transmission Setup -> PWM/Digital outputs section. The 3rd slope time is variable to provide a variable time for clutch engagement on a PWM shift solenoid based on load. This cannot be easily tuned by line pressure on some modern transmissions and therefore this control has been added to accommodate the small percentage of modern transmissions that require this type of control.

4.8 Additional Features

4.8.1 Stepper Motor Setup

The stepper motor control table is intended to be used for controlling the differential on some AWD vehicles. This is not a normal transmission controller function and should not be used by any individual who has not specifically requested this feature. The stepper motor table allows for complete control of a stepper motor. The polarity of each output and selection of 1A, 1B, 2A, and 2B is in the PWM or Digital outputs. Once the poles have been chosen and the stepping methods have been chosen, stepper motor control tuning may be performed. The TCU will compare the wheel speeds across the differential to reach a programmed level of slip. Overtemp will stop driving the stepper motor at a programmable temperature and the PID loop is provided for advanced users.

4.8.2 Datalogging

Datalogging is one of the most powerful features offered by the TCU. It allows a user to see transmission behavior and engine behavior. The extra analog and digital inputs offered by

the TCU also allows the TCU to be used as a general datalogging device for any other vehicle functions you may wish to record.

To begin a datalog, do the following:

1. The TCU power must be on and the TCU must be communicating/online with your computer.
2. Go to the datalog pull down/explorer folder. Double click the Start Logging button.
3. A window will appear with the option to “Start Logging” and several Datalogging rates will be offered. Choose your datalogging rate and click on the “Start Logging” button. When prompted, choose a file name and location for your datalog. As with calibration files you may want to choose a descriptive name including the time, date, and/or application of your datalog. Once you have chosen a name and location, click save or press enter.
4. The software and your computer will now begin datalogging. You may view the transmission behavior through the monitor screen while datalogging.
5. When you have completed your datalog, you may click on the “stop logging” button. This will complete your datalogging session and save your datalog file to the location you specified.

To view a datalog, do the following:

1. Datalogs may be viewed with the Datalog Viewer software, Microsoft Excel or any other program that can handle the tab delimited values contained in the datalog. The Datalog Viewer software offers a much stronger set of capabilities and datalogging viewing options; however we understand that many users may wish to use other tools or analysis methods which do not fall within the scope of the TCU software. The datalog files use the file extension .tlg which is associated with the Datalog Viewer Software; however this does not prevent users from opening the same file in Microsoft Excel.
2. To use the Datalog Viewer software, go to the datalog pull down/explorer folder. Double click the view button. If you know the location of the datalog file, you may also open this file directly, which will automatically start the Datalog Viewer software.
3. If the Datalog Viewer software is not being opened with a file, a blank screen will appear. Click the “load” button or go to File-> Open. Choose the file location and name and click open or hit enter.
4. Initially, your datalog will appear in graph view. To begin viewing the data, click in the boxes next to the datafields you wish to see near the top of the screen. You may view this data in a tabular view by clicking the table view button on the icon menu.
5. Several zooming options are available by right clicking your mouse button. You may zoom in by clicking on a beginning time and an ending time for your graph selection. You may also choose to view all the data, zoom to a percentage, or zoom to a particular time period.

6. Please refer to the hotkeys list for a complete listing of key options for navigating the datalog menu.
7. You may load another datalog or continue tuning at any time.

4.8.3 Flash Upgrade Procedure

The flash upgrade procedure should not be used unless well understood. The flash upgrade procedure is not intended to change a calibration file or to tune the transmission controller. The flash upgrade procedure is only used for firmware upgrades. Firmware upgrades directly modify the code in the control systems of the transmission controller. The ability to flash upgrade the firmware allows the transmission controller to be upgraded in the field so that new features can be added and possible problems can be remedied.

To perform a flash upgrade, do the following:

1. The TCU power must be on and the TCU must be communicating and online with your computer.
2. To begin a flash upgrade, select Communications -> flash upgrade from the explorer menu or Communications -> flash upgrade -> flash upgrade TCU from the toolbar. Once this form opens, no other forms will be available. This is done to protect the TCU. At this form, the firmware major and minor revision will be displayed. The hardware revision will also be displayed.
3. To begin flashing the transmission controller, click the "Open Flash File to Begin" button. This will open a file selection menu. Only *.rom files can be opened and the correct file must be chosen for a proper upgrade. If you are unsure about which rom file you should use, contact technical support first. When using newer software with an older controller (or vice versa), the unit may not communicate or properly find the com port until it is flash upgraded. You may need to manually select the com port. Once the correct file has been selected, click open in the current menu.
4. A warning message will appear with a warning not to turn the power off until the upgrade is complete. Follow these instructions explicitly. Heed this warning! Click the yes button if you are prepared to flash the unit.
5. The initial flash upgrade screen will display a progress bar and provide some information about the flash procedure. Once complete, the last line of text will read "Flash upgrade complete!"
6. If you experience a box that appears saying "error writing to unit please check connection and try again." You will need to turn the unit off and on again, check all your connections and start over with these directions. Your unit will not begin to function properly again until a successful flash has been completed.

4.8.4 Com Port Manual Configuration (for Flash Upgrading Only)

Manually configuring a com port for use with the TCU software is a task for advanced users only. Generally if the TCU software is unable to communicate with the TCU, the reason has nothing to do with com port selection. For this reason, use the manual com port setting as a

last resort to a communication problem. Please do not try to use this feature if you do not fully understand what a com port is and which com port you wish to set.

The only time that a com port should need to be manually set is during a flash upgrade procedure. It is possible to have software newer than the firmware in a TCU such that the TCU will no longer go online with the TCU. In this case, the com port should be determined from your computer hardware settings and programmed under communications >> Flash Upgrade >> Select Port Manually.

4.8.5 Diagnostic Trouble Codes

The TCU offers basic diagnostic trouble codes for all analog inputs, battery voltage and TCU temperature. These diagnostic measures have been provided to alert the user of potential problems and prevent premature failure of the TCU or transmission. A diagnostic trouble code failure will occur in the following conditions:

1. An analog input value is above the high failure value or below the low failure value as programmed for each analog input.
2. Battery voltage exceeds 25 volts.
3. Unit temperature exceeds 120°C (248°F) or falls below -30°C (-22°F).

A simple failure flag will appear when datalogging and when viewing the monitor screen. To view the details of the failure or to clear the failure value, you must:

1. Go to the communications pull down/explorer folder. Double click the diagnostic trouble codes button.
2. You will see a matrix of possible diagnostic trouble codes. These failures should be taken seriously and investigated (especially the TCU overtemp and battery overvoltage warnings). To ignore these values could lead to failure of the transmission, engine or TCU.
3. If you wish to clear these values after investigating and solving the problem, click the clear button.

4.8.6 Password Protection

The TCU offers password protection. This protection is offered primarily for dealers who wish to prevent customers from altering their calibration and/or competitors from using their calibrations. Once a password has been set, information cannot be retrieved or altered directly on the unit. However, a user may still overwrite the entire calibration with a new calibration at which point the password protection will have been overwritten. Doing this will cause the protected calibration to be irretrievably lost, so proceed with care. Any user may completely overwrite this information with a different calibration but that user would need to start tuning from nothing.

If a password is lost, it can be retrieved by technical support staff using a permission key issued by the software. This password has a high level of encryption and a person (s) wishing to receive a new password must have all of the information from the original purchaser and pass a verbal test to receive a calibration.

4.8.7 Monitor Screen

The monitor screen offers a wealth of information regarding the current status of the engine, transmission and TCU. To get to the monitor screen, go to the communications pull down/explorer folder and select monitor. Alternatively, the hotkey CTRL-M will also work. A large screen will appear with several gauges and a full listing of TCU input/output status. The gauge units and increments may be changed with the setup button available when the monitor screen is open.

4.8.8 Lightweight Monitor Screen

A versatile lightweight monitor is also offered to provide the same information in a more compact format. The lightweight monitor screen is less visually entertaining and is more difficult to read for most users but some installers may wish to use this monitor screen during the tuning process or while diagnosing a perceived problem. The lightweight monitor screen can be reached from the communications drop down/explorer menu.

4.8.9 Test Mode

Test mode allows a user or installer to test the function of some features before wiring them. This can be very useful for installers or users who do not wish to wire switches and/or do not use these functions frequently. To get to test mode, go to the communications drop down/explorer menu and choose test mode.

This form is to be read in rows. The check boxes in options 1-7 must be checked to allow each option to be turned on or off. Once a box has been checked, an installer or user may turn on that option by clicking the "on" or "off" mode boxes. The "Set TPS %" function allows a forced value of Throttle position to be programmed. Simply type in a value and hit the "set" button to activate a desired percentage. The analog input corresponding to TPS must be disabled before this function will work.

The "perform an upshift now" and "perform a downshift now" functions allow an installer or user to command an upshift or downshift without any wiring. This can be very useful for testing manual modes and how they will work in an application. This also gives a user or installer great freedom to test transmission function before completing the vehicle wiring or even if no upshift/downshift buttons are intended the shifts can be tested. The test mode upshift and downshift commands only work when manual mode is enabled.

4.8.10 Toolbar Setup

The TCU software has an icon based toolbar at the top of the screen. This toolbar is offered to simplify access to common functions and is fully customizable. To customize this toolbar, go to the software setup pull down/explorer folder. Double click on the toolbar setup button. From this menu you may add or subtract toolbar buttons and separators. Ideally you will want to remove functions you do not use often and will want to add functions that you do use frequently.

4.8.11 Units Selection

The TCU software can display units in standard, metric or a combination of units if you desire. To alter the unit display information, go to the software setup pull down/explorer folder. Double click on the unit selection button. From this menu you may select the units you wish to use.

4.8.12 Tire Diameter Wizard

The calculate tire diameter wizard helps users determine their overall tire diameter from the popular tire format of 275/55R17 where 275 represents a 275mm width, 55 represents a 55% tire sidewall height to width ration and R17 represents a 17 inch wheel diameter. Simply type the appropriate values into this calculator and hit enter after each field for the wizard to calculate your overall tire diameter.

4.8.13 Sensor Calibration Wizard

The sensor calibration wizard is intended for advanced users who may have information from documentation about a sensor but do not know how to translate it into usable data for the TCU. Using the fluid temperature setting, a user can take a resistance vs. temperature chart and arrive at the appropriate voltages. The calibration wizard will calculate this based on analog inputs 5-6 (directly wired to sensor) or with analog inputs 1-4. If the sensor is being piggybacked on analog inputs 1-4, the resistance must be measured across the wires going to the sensor with the sensor unplugged. This will determine the resistance value across the ecu (known as a pullup resistor) so that the voltages can be properly determined.

5. Chapter 3 – Software Function List

5.1 Overview

This chapter will explain some of the most important input and output functions and some hints on wiring the devices that correspond to those functions. The universal nature of the TCU prevents an explanation of every possible input and output; however those inputs and outputs that are required or very common in the control of electronic automatic transmissions will be covered.

5.2 Inputs

5.2.1 Analog Inputs

The TCU has six analog inputs which read a 0-5v scaled input. Analog inputs are important for a variety of sensors such as throttle position (TPS), Manifold Absolute Pressure (MAP), Engine Coolant Temperature (CLT) and Transmission Fluid Temperature (TFT). An analog input can also be used with stock steering wheel buttons, like cruise control and volume control, of some vehicles where different buttons correspond to different voltages. These voltages can be programmed to perform upshifting and downshifting when in manual mode.

Analog inputs 1-4 have been designed so that they can piggyback any sensor from an engine controller or directly measure most sensors. Analog inputs 1-4 should not be used to directly measure any temperature sensors or other resistance based 2-wire sensors. Analog inputs 5-6 have been designed so that they can measure any sensor directly. Analog inputs 5-6 should not be used to piggyback any sensors from an engine controller. Analog inputs 5-6 should be used to directly measure any temperature sensors or other resistance based 2-wire sensors. The proper use for analog inputs 1-6 are visually represented in *Table 6*.

Table 6. Analog Input Matrix.

	Analog Inputs					
	1	2	3	4	5	6
Use to piggyback any sensor from engine controller.	•	•	•	•		
Use to measure any sensor directly except temperature sensor or other resistance based 2-wire sensors.	•	•	•	•		
Use to measure any sensor directly.					•	•
Use to measure temperature sensors or other resistance based 2-wire sensors directly.					•	•

Disabled/Voltage Only:

This input has no programmed function but will display the input voltage while monitoring and datalogging with the TCU.

Throttle Position Sensor (TPS):

The throttle position sensor is key to transmission control. Throttle position transmits the driver's desired acceleration to the TCU. By default this is interpreted by the TCU as engine load and is a primary parameter when determining shift points, shift firmness and shift speed. A MAP sensor may be substituted for TPS where no TPS is available or in turbocharged applications.

Almost all TPS's are rotary potentiometers (rotating variable resistors) with 3 connections. One connection is for a ground reference, another connection is for a +5v reference voltage and the final connection is for signal output. The analog input pin from the TCU will be wired to the signal output pin of the TPS. The TCU wiring harness provides a +5v reference voltage signal (red wire with white stripe) and a ground reference signal (black with white stripe). The TPS output pin should increase in voltage as you open the throttle. A typical closed throttle voltage value is .45v. A typical wide open throttle (WOT) value is 4.5v.

A switch type TPS will not provide the TCU with a linear voltage output and should **never be used**. To properly wire a TPS, you must know the function of each pin.

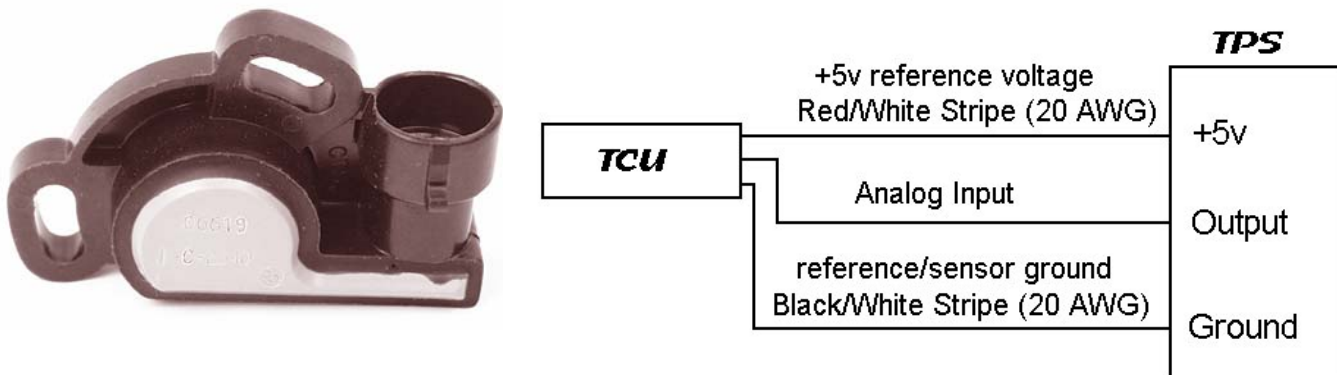

Figure 18. TPS reference picture and pinout diagram

Manifold Absolute Pressure (MAP) Sensor:

The map sensor is a secondary sensor for transmission control. If you are using TPS for load determination, the MAP sensor only functions for datalogging and extra features. If you use the MAP sensor for load determination the signal is interpreted by the TCU as engine load and is a primary parameter when determining shift points, shift firmness and shift speed. The MAP sensor is most useful for load determination where no TPS sensor is available or in turbocharged/supercharged applications. In boosted applications, the MAP sensor is typically

only used for line pressure and accumulator pressure load determination because MAP is a better indicator of engine power. TPS is typically still used for the part throttle shift table and torque converter lockup.

Most MAP sensors vary resistance with pressure and have 3 connections. One connection is for a ground reference, another connection is for a +5v reference voltage and the final connection is for signal output. The analog input pin from the TCU will be wired to the signal output pin of the MAP sensor. The TCU wiring harness provides a +5v reference voltage signal (red with white stripe) and a ground reference signal (black with white stripe). The MAP sensor output pin should increase in voltage as pressure increases.

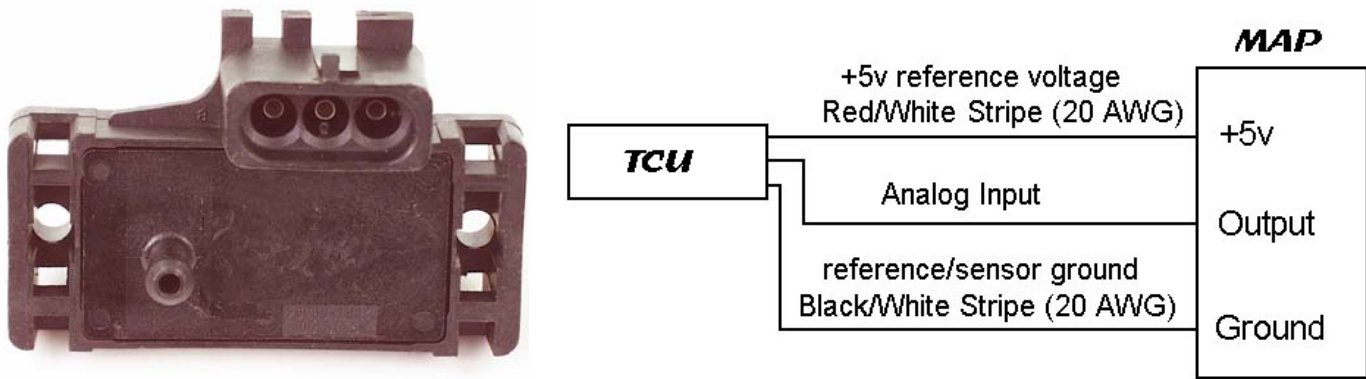

Figure 19. MAP reference picture and pinout diagram

Engine Coolant Temperature (CLT) Sensor & Transmission Fluid Temperature (TFT) Sensor:

The CLT & TFT sensors are secondary sensors for transmission control. Either or both CLT & TFT sensors can be programmed to alter line pressure, tcc lock/unlock and upshift/downshift behavior based on temperature. This can be especially useful for abnormally warm or cold climates. Though we do recommend the use of a CLT & TFT sensor, it is not required for transmission operation.

Most CLT & TFT sensors vary resistance with temperature and have 2 connections. One connection is for a ground reference and the other connection is for signal output. An analog input pin from the TCU will be wired to the signal output pin of the CLT sensor and another analog input pin from the TCU will be wired to the signal output pin of the TFT sensor. The TCU wiring harness provides a ground reference signal (black with white stripe) for both sensors. Both the CLT & TFT sensors should have a decreasing voltage output as temperature rises.

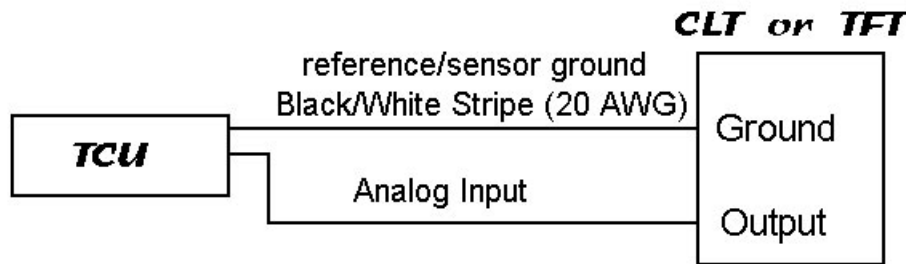

Table 7. CLT/TFT resistance vs. temperature chart

Figure 20. CLT/TFT reference picture and pinout diagram

Temp, °C	Temp, °F	Resistance, Ω	TCU Input Voltage, V
-40	-40	100707	4.95
-20	-4	28667	4.83
0	32	9423	4.52
20	68	3515	3.89
40	104	1459	2.97
60	140	667	2.00
80	176	332	1.25
100	212	179	.76
120	248	103	.47
140	293	56	.26

Pressure Sensor:

Some transmissions are equipped with a pressure sensor. This type of input allows for trims based on pressure or simple monitoring of the pressure sensor.

RFE

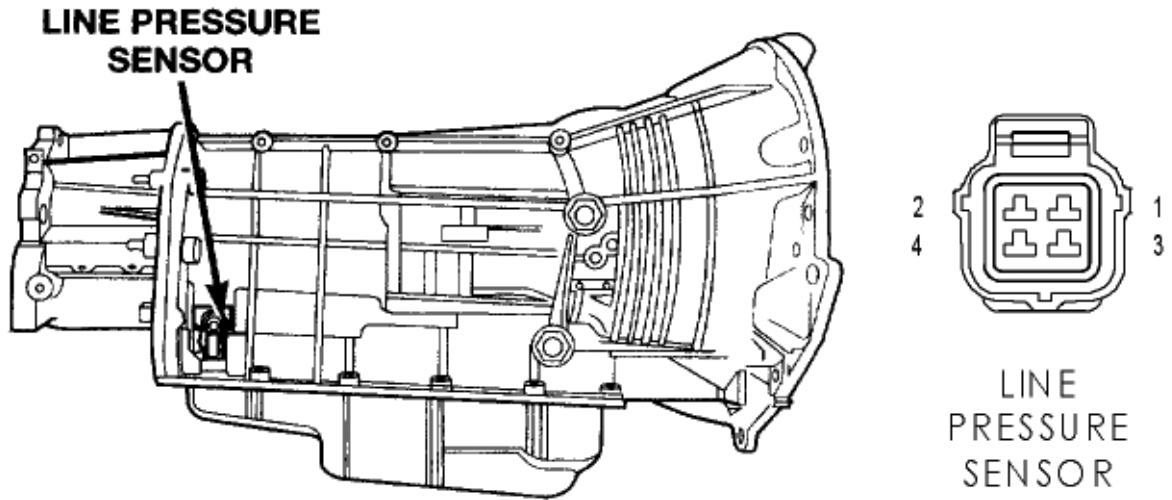

LINE PRESSURE SENSOR (NGC) - 4 WAY

CAV	CIRCUIT	FUNCTION
1	K900 18DB/DG	SENSOR GROUND
2	F856 18YL/PK	5 VOLT SUPPLY
3	T38 18YL/BR	LINE PRESSURE SENSOR SIGNAL
4	-	-

Figure 21. Line Pressure Sensor Location & Wiring

Dial/Potentiometer Trim:

A potentiometer may be wired to an analog input on the TCU as a trim tool. This allows a user to simply turn a dial and change parameters like line pressure, accumulator pressure, upshift/downshift points, tcc lockup, etc.

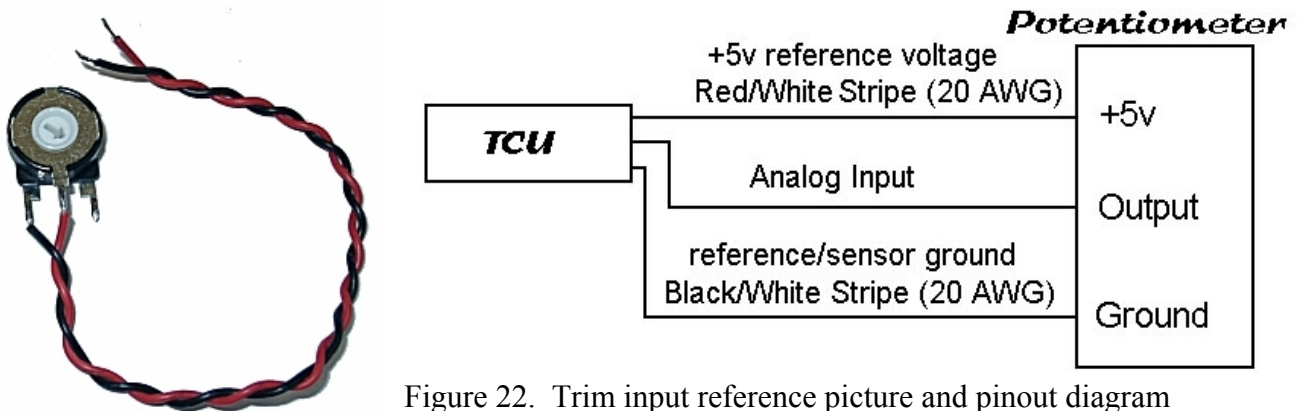

Figure 22. Trim input reference picture and pinout diagram

Multiplexed Steering Wheel Buttons

(stock steering wheel controls that can be used as triggers):

Some vehicles have buttons on their steering wheels to control functions like cruise control or radio buttons. Typically these controls will come back to one wire from the steering wheel. Many functions can be built into a single wire because each button has a different resistance and therefore causes a different voltage to be sent to the stock computer. Two different voltages can be set to upshift and downshift thereby allowing you to use your stock steering wheel buttons for manual mode upshifting and downshifting. This does require a switch to be wired to a relay and a digital input. The relay is used to disconnect your steering wheel line from normal radio or cruise control operation to use for the TCU upshift/downshift feature. The digital input instructs the TCU to enter manual mode and recognize the steering wheel buttons as upshift/downshift commands.

Several hard-coded factors should be considered:

- Button debounce is set by the digital debounce parameter in the digital inputs form.
- The horn output will trigger below 0.5 volts. You must set a digital output to activate the horn if you are using the horn circuit for shifting and wish to retain correct horn function.
- The upshift/downshift button will reset when it goes below .14 volts or above 4.7 volts (at these voltages, the TCU understands that you have disengaged the upshift/downshift button).
- The range of activation is +/- .25 volts from your set point. So if you instruct the TCU to upshift at 3.5 volts, all values from 3.25-3.75volts are considered a valid upshift command.

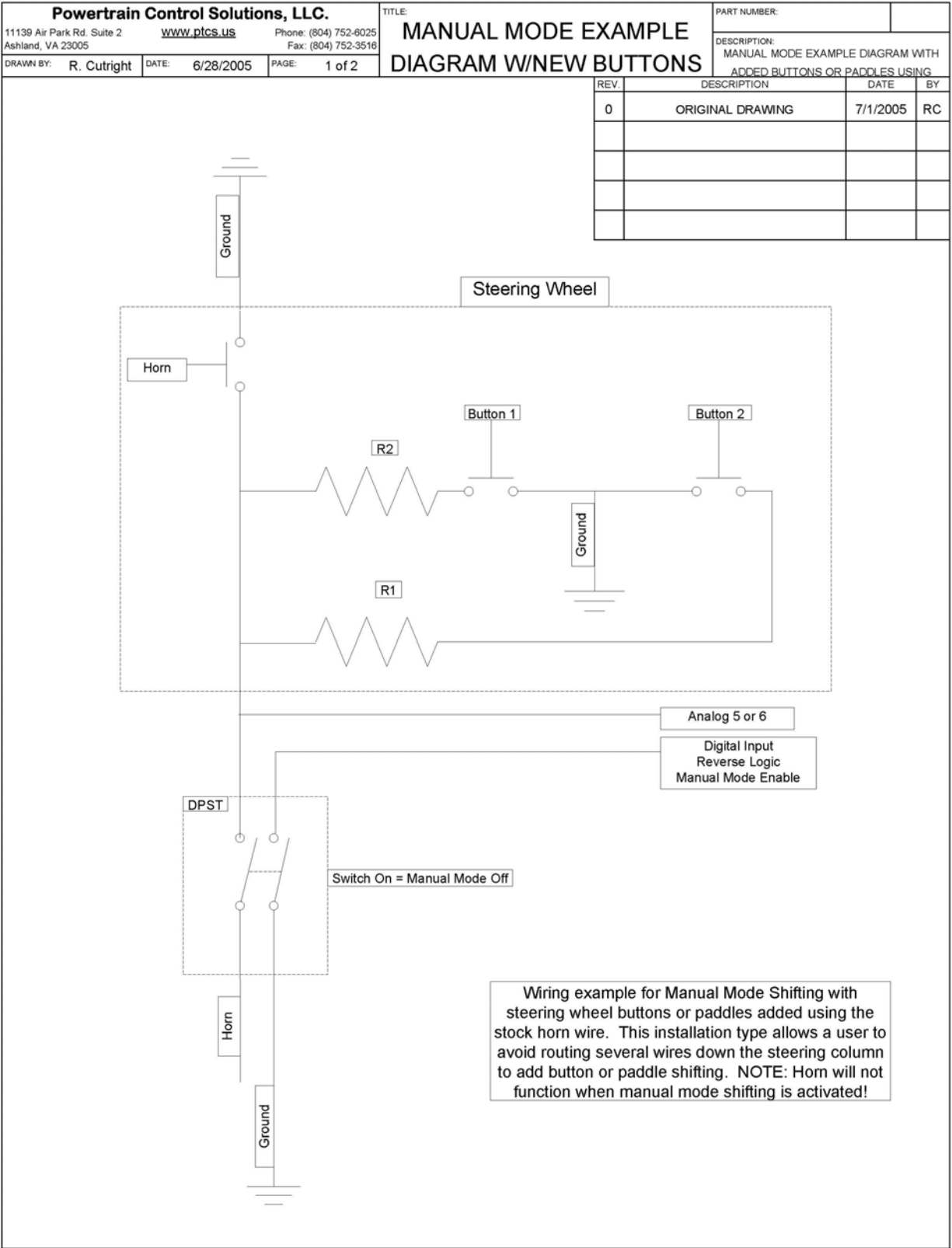

Figure 23. Manual Mode Example Diagram w/new buttons

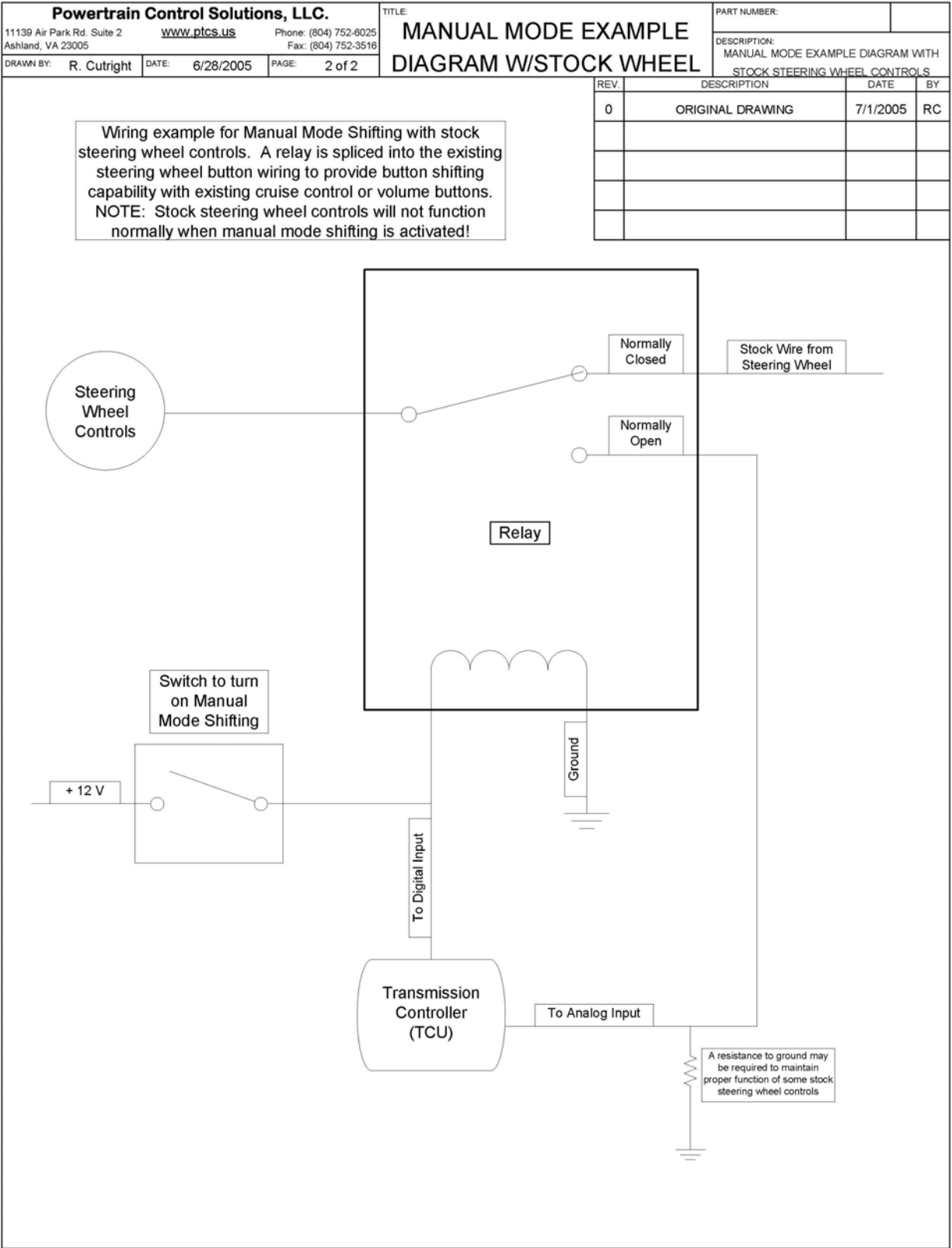
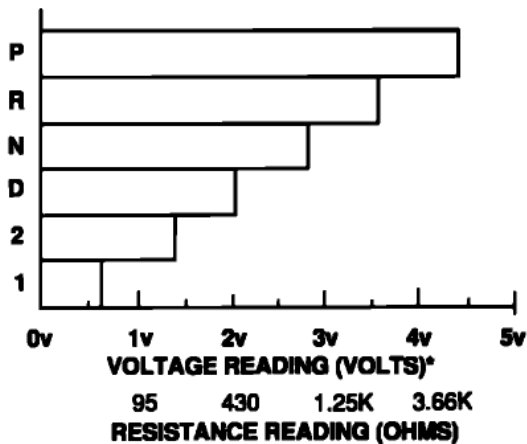

Figure 24. Manual Mode Example Diagram w/stock wheel

Analog Range Switch:

Some transmissions are equipped with an analog range switch. These transmissions correlate specific voltages on a single wire to different lever positions. If the transmission is equipped with this type of range switch, an analog range switch must be wired and properly programmed for the TCU to properly determine the selected lever positions. This programming can be done based on service manual information, as in Figure 25 below, or by monitoring the appropriate analog input while moving the shift lever to each detent.

TRANSMISSION POSITION



MLP SENSOR DATA* Voltage values calculated for VREF = 5.0v (These values may vary \pm 15% due to sensor and VREF variations)

Transmission Shift Position	Voltage* Volts	Resistance Ohms
P	4.41	4.16K
R	3.60	1.44K
N	2.83	733
D	2.09	401
2	1.37	211
1	.68	81

Figure 25. Analog Range switch example from a Ford E4OD application

5.2.2 Digital Inputs

Digital inputs may only provide two states, on or off. They may be programmed to be active when high (+5v or greater) or low (gnd). Digital inputs may also be programmed for momentary (i.e. a button that is only active when depressed) or toggle (for buttons or switches that stay active once depressed or switched). Digital debounce is the time required to activate the button.

Disabled:

This input has no programmed function but will display the input state while monitoring and datalogging with the TCU.

Upshift:

This digital input will issue an upshift command to the TCU. This command is only effective when in manual mode.

Downshift:

This digital input will issue a downshift command to the TCU. This command is only effective when in manual mode.

Brake Light:

Stock transmission controllers unlock the torque converter when the brake light or brake switch is triggered. We recommend wiring a digital input to your brake light or brake switch and programming a digital input accordingly. You may wire an additional switch to this digital input or to another digital input programmed as the brake light input if you wish to unlock the torque converter with the touch of a button or switch.

Snow Mode:

When enabled, this digital input will provide 1st gear lockout. The transmission will start in 2nd gear to assist in poor weather driving.

Manual Mode:

When enabled, this setting allows the user to upshift or downshift with the press of a button. An analog multiplexed steering wheel input or two digital inputs may be used for the upshift and downshift commands. Two modes are available:

Smart Mode. When in smart mode, the transmission controller will still use your programmed shift tables. However you will be able to choose the maximum gear to shift into. So if the driver has selected first gear, the engine will rev up to the rev-limiter and continue at this rpm until the driver issues an upshift command. If the driver has selected fourth gear and slows down to the programmed 4-3 shift point, the transmission will downshift to third gear. Similarly, if the driver has selected fourth gear and comes to a stoplight, the transmission will downshift to first gear automatically.

True Mode. When in true mode, the transmission controller will only upshift or downshift when issued a command to do so. So if the driver has selected first gear, the engine will rev up to the rev-limiter and continue at this rpm until the driver issues an upshift command. If the driver has selected fourth gear and slows down to the programmed 4-3 shift point, the transmission will remain in fourth gear. Similarly, if the driver has selected fourth gear and comes to a stoplight, the transmission will remain in fourth gear. The WOT upshift RPM points will act as downshift rpm limiters to prevent accidental downshifting that would otherwise over-rev the engine.

Dyno Mode:

When enabled, this mode will allow you to lockup the torque converter and choose a gear for dynamometer use. Locking up the torque converter will lower transmission loss and may increase power numbers on the dyno. Typically you will want to choose a gear that is 1:1 to use for the dyno as this gear ratio usually has the smallest amount of loss in the transmission. Both parameters are configurable. All upshifts/downshifts will occur at the value specified by 0% TPS in the upshift/downshift tables. Upshifts will occur until reaching the desired gear specified in the dyno mode form. TCC lockup will occur based on the speed set in the dyno mode form.

Calibration B:

When enabled, this allows a second full calibration to be used. This can be especially useful for occasional racing, towing, four wheeling, fuel economy, etc. You will need to fully tune this calibration as should be done for calibration A. A copy calibration function is available in the tuning menu which can greatly speed the process of tuning your second calibration.

4wd Low:

When enabled, this acts as an output speed divisor. This is for 4wd applications where the transfer case and the speed output are connected to the output of the transmission. Without any correction, this would cause the speedometer to read abnormally high. The correction factor enabled by this digital input must be programmed in the gear ratio tables. This input should be wired to the 4wd low button or (if lever activated) to the 4wd low sensor in the transfer case or shift lever.

Cancel Overdrive:

This selection cancels the highest gear. This cancellation occurs regardless of other parameters.

Gear Select:

Gear selects form the logic that determines gear selection in most automatic transmissions. Most transmissions have several gear select inputs. Many gear selects combined form the range selection logic for an automatic transmission. In the example below, gear selects 1, 2 & 3 should be programmed to correspond to the digital inputs for pressure switches A, B & C respectively.

Table 8. Gear Select Chart

Range Lever Position	Gear	Pressure Switches (input)		
		“A”	“B”	“C”
Park		OFF	ON	OFF
Reverse		ON	ON	OFF
Neutral		OFF	ON	OFF
OD	1 st	OFF	ON	ON
	2 nd			
	3 rd			
	4 th			
D	1 st	OFF	OFF	ON
	2 nd			
	3 rd			
2	1 st	OFF	OFF	OFF
	2 nd			
1	1 st	ON	OFF	OFF
	2 nd			

5.2.3 Speed Inputs

Speed Inputs. The only **required** speed input is driven wheel speed.

- 12.8. Engine RPM must be directly calculated and you must input the number of cylinders to receive the correct RPM value.
- 12.9. Torque converter RPM can be directly measured directly on some transmissions and you must enter the number of pulses per revolution to receive the correct RPM value. Many applications can simply choose a calculated torque converter RPM value which does not require a value for the number of pulses per revolution but does require driveshaft speed and the correct gear ratios for your transmission.
- 12.10. Driveshaft RPM must be directly measured and you must enter the number of pulses per revolution.
- 12.11. Driven wheel speed can be calculated only if you have driveshaft RPM, driven tire diameter and final drive ratio. Driven wheel speed can also be measured directly and you must enter the number of pulses per mile for proper TCU function.
- 12.12. Non-driven wheel speed can only be measured directly and you must enter the number of pulses per revolution for non-driven speed to display correctly.

The TCU has one speed output to send a speed signal to the device of your choice. The most common application for this output is driving an electronic speedometer.

To accommodate a wide range of speed sensor applications, speed input trigger levels and filter values are also programmable. This trigger level and filtering programmability helps eliminate false triggering in a noisy environment or no triggering with a low speed or weak signal. Though this parameter can be difficult to understand and deal with, it allows the TCU to accommodate nearly all available sensors.

Table 9. Speed Input Matrix.

	Directly measurable	Can be Calculated	Parameters for direct measurement	Parameters for calculation
Engine RPM	•		# of Cylinders	NA
TCC Speed	•	•	# of teeth	Gear Ratios Driveshaft Speed
Driveshaft Speed	•		# of teeth	NA
Driven Wheel Speed	•	•	#of teeth	Driveshaft Speed Final Drive Tire Diameter
Non-Driven Wheel Speed	•		#of teeth	NA

5.2.4 Frequency Range Switch

The frequency range switch must use one of the four speed input wires and consequently disables that speed input from reading normal speed values. This dedicated function is for a small number of transmissions that use frequency to determine lever position. The appropriate duty cycle range should be programmed in the Frequency Range Switch Table. This function must be enabled from the Frequency Range Switch Table to work properly.

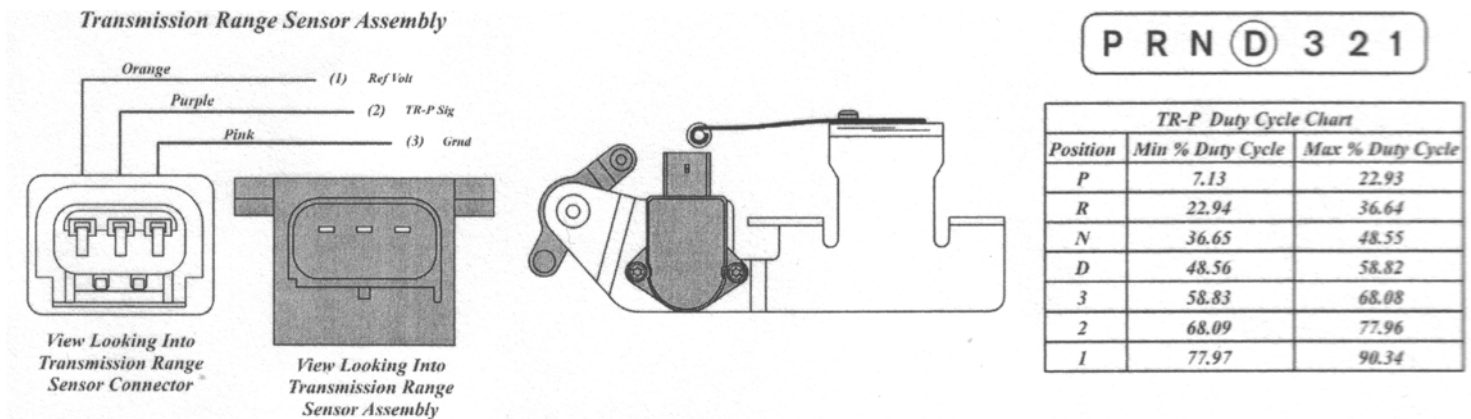

Figure 26. Frequency Range switch example from a Ford 5R110 application

5.3 Outputs

5.3.1 Digital Outputs

Digital outputs may only provide two states, on or off. They may be programmed to output power or a ground. Digital Outputs 1, 2 & 3 may also function as PWM outputs if desired.

Disabled:

This digital output will perform no function.

TCC Lockup:

This output will activate your TCC lockup solenoid. On some transmissions this alone will lockup your torque converter. On other transmissions it must be used in conjunction with a

PWM TCC solenoid for smooth torque converter lockup. Many transmissions no longer use this solenoid, simply opting for a PWM TCC solenoid only.

Calibration B Indicator:

This output is driven when Calibration B is selected. It can be used to activate an LED to indicate that Calibration B is in use.

Dyno Mode Indicator:

This output is driven when Dyno Mode is selected. It can be used to activate an LED to indicate that Dyno Mode is in use.

Snow Mode Indicator:

This output is driven when Snow Mode is selected. It can be used to activate an LED to indicate that Snow Mode is in use.

Overdrive Cancel Indicator:

This output is driven when Overdrive Cancel is selected. It can be used to activate an LED to indicate that Overdrive Cancel is in use.

Multiplex Horn/Upshift/Downshift:

This output is driven by the multiplex analog input. This output can be used to trigger a horn when the multiplex horn/upshift/downshift analog input is less than .5 volts.

TCC Lockup Status:

This output is driven when TCC lockup is active. This output can be used to activate an LED to indicate that the TCC is locked or for other functions correlating to TCC lockup.

Speedometer Drive:

Some speedometers require a strong signal may not be driven correctly by the normal speedometer output of the TCU. In such cases, a digital output may be programmed to output the same speed signal. This function is only available on digital output 4, 5, or 6. The output type should be programmed to ground and this situation is typical of some GM speedometer applications.

Shift Solenoids:

Shift solenoids form the output logic that determines gear selection in an automatic transmission. There will be several shift solenoid outputs for each transmission. Shift solenoids A, B, C, D, E, & F may be selected and the output logic should be programmed in the gear selection and solenoid output chart in the TCU software.

Table 10. Shift Solenoid Example Chart

Range Lever Position	Gear	Shift Solenoids (output)	
		“A”	“B”
Park		ON	ON
Reverse		ON	ON
Neutral		ON	ON
OD	1 st	ON	ON
	2 nd	OFF	ON
	3 rd	OFF	OFF
	4 th	ON	OFF
D	1 st	ON	ON
	2 nd	OFF	ON
	3 rd	OFF	OFF
2	1 st	ON	ON
	2 nd	OFF	ON
1	1 st	ON	ON
	2 nd	OFF	ON

Stepper Outputs:

This function is available to drive a stepper motor. This usually requires 4 outputs (digital or PWM) and the stepper motor setup section must be programmed appropriately in the TCU software.

5.3.2 PWM Outputs

PWM outputs (pulse width modulated) provide a large amount of control over electrical devices. With a simple filtering circuit they can be used to provide an analog voltage output as well. In transmission control, they are most commonly used to control solenoid positions for pressure control. They may be programmed to output power or ground. The output frequency should be matched to the solenoid or device being used to work properly.

PWM vs. Shift Cut:

This function activates an output for a programmed amount of time with a programmed PWM duty cycle value. Each shift is programmable and upshifts only, downshifts only or upshifts/downshifts may be selected for activation.

Line Pressure:

This output is controlled by the Load vs. Line pressure table in each calibration. In these tables you can choose duty cycle (solenoid opening) vs. engine load.

Accumulator Pressure:

This output is controlled by the Load vs. Accumulator pressure table in each calibration. In these tables you can choose duty cycle (solenoid opening) vs. engine load.

TCC Lockup:

This output is controlled by the TCC lockup parameters and the TCC Lockup/Unlock table in each calibration. In the TCC Lockup/Unlock table you can select torque converter lockup and unlock based on engine load and speed. The TCC lockup parameters table provides some additional temperature based features.

TCC Pressure Control:

This output is controlled by the PWM TCC Pressure Control chart in each calibration. Several parameters can be adjusted to make for a smoother or harsher torque converter lockup and unlock.

Calibration B Indicator:

This output is driven when Calibration B is selected. It can be used to activate an LED to indicate that Calibration B is in use.

Dyno Mode Indicator:

This output is driven when Dyno Mode is selected. It can be used to activate an LED to indicate that Dyno Mode is in use.

Snow Mode Indicator:

This output is driven when Snow Mode is selected. It can be used to activate an LED to indicate that Snow Mode is in use.

Overdrive Cancel Indicator:

This output is driven when Overdrive Cancel is selected. It can be used to activate an LED to indicate that Overdrive Cancel is in use.

PWM vs. Gear:

This output allows a programmable PWM duty cycle for each available gear.

Multiplex Horn/Upshift/Downshift:

This output is driven by the multiplex analog input. This output can be used to trigger a horn when the multiplex horn/upshift/downshift analog input is less than .5 volts.

TCC Lockup Status:

This output is driven when TCC lockup is active. This output can be used to activate an LED to indicate that the TCC is locked or for other functions correlating to TCC lockup.

Shift Solenoids:

Shift solenoids form the output logic that determines gear selection in an automatic transmission. There will be several shift solenoid outputs for each transmission. Shift solenoids A, B, C, D, E, & F may be selected and the output logic should be programmed in the gear selection and solenoid output chart in the TCU software.

Table 11. Shift Solenoid Example Chart

Range Lever Position	Gear	Shift Solenoids (output)	
		“A”	“B”
Park		ON*	ON*
Reverse		ON*	ON*
Neutral		ON*	ON*
OD	1 st	ON	ON
	2 nd	OFF	ON
	3 rd	OFF	OFF
	4 th	ON	OFF
D	1 st	ON	ON
	2 nd	OFF	ON
	3 rd	OFF	OFF
2	1 st	ON	ON
	2 nd	OFF	ON
1	1 st	ON	ON
	2 nd	OFF	ON

PWM Shift Solenoids:

Shift solenoids form the output logic that determines gear selection in an automatic transmission. There will be several shift solenoid outputs for each transmission. PWM Shift solenoids A, B, C, D, E, & F may be selected and the output logic should be programmed in the gear selection and solenoid output chart in the TCU software. PWM shift solenoids differ from standard shift solenoids because they offer variable duty cycle during the shift event. A standard shift solenoid is only on or off (100% duty cycle or 0% duty cycle). These programmable variable duty cycle ramps can be altered based on load with the PWM Shift Solenoid Slope Period Table in each calibration. When programming these slopes, remember to check the advanced solenoid output table in the gear selection and solenoid output table and program a shift period greater than the total of the PWM shift slope.

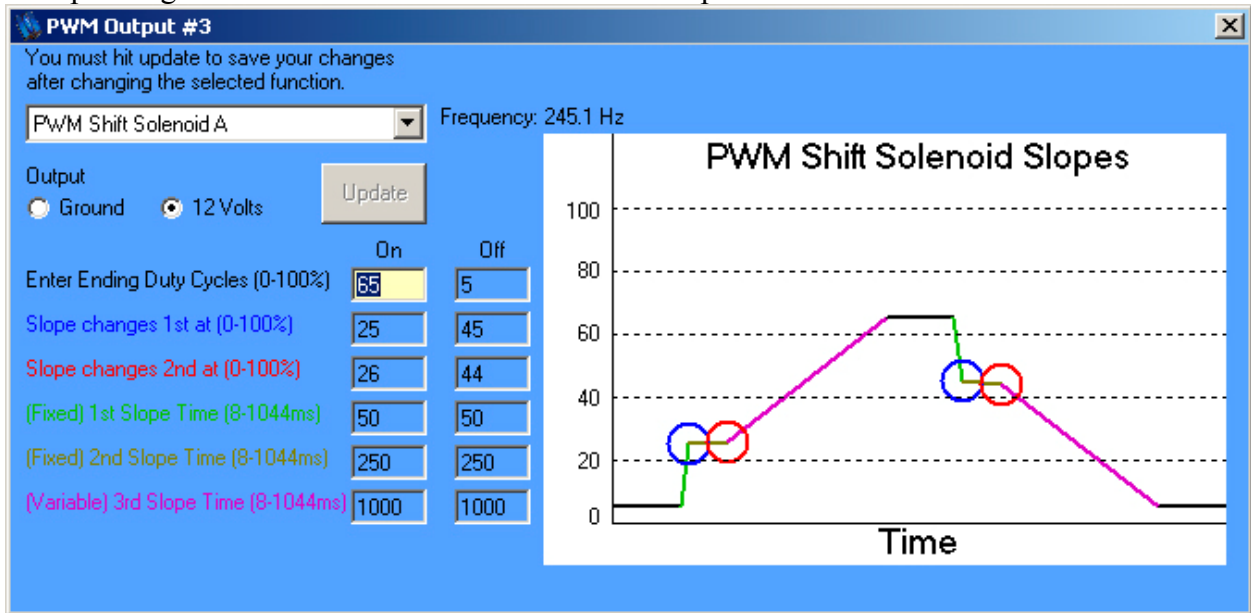

Figure 27. PWM Shift Solenoid Output Example

Trim Solenoids:

Trim solenoids are provided for specific transmissions that use on-going and off-going trim systems.

PWM vs. Function:

A 16 point table of duty cycle may be programmed vs. any of the variables listed below:

RPM	Turbine Speed	Shaft RPM	VSS	VSS2	TPS	MAP
Coolant	Fluid Temp1	Fluid Temp2	Vehicle Slip	TCC Slip	Analog1	
Analog2	Analog3	Analog4	Analog5	Analog6		

This is a powerful feature that can be programmed to trigger fans based on temperature, nitrous or boost control based on boost, provide an rpm based trigger, etc.

5.4 CAN Communication

The TCU offers J1939 compatibility, current compatibility with some CAN buses and future compatibility with some CAN buses. In some cases, variables like TPS, engine RPM and VSS can be determined through CAN rather than with direct inputs. The CAN communication form allows the selection of a J1939 bus. If the J1939 bus is selected, standard J1939 format messages can be sent and received by the TCU. Some of these receive options are listed on this form, for more detail contact technical support. The proprietary CAN bus can send and receive messages with our other products. Additional CAN bus support may be added in the future.

REV.	DESCRIPTION	DATE	BY
0	ORIGINAL REVISION	5/10/04	JB
1	NEW FORMAT	5/23/05	RC
2	ADDED INPUT/OUTPUT WIRES	12/21/05	JT

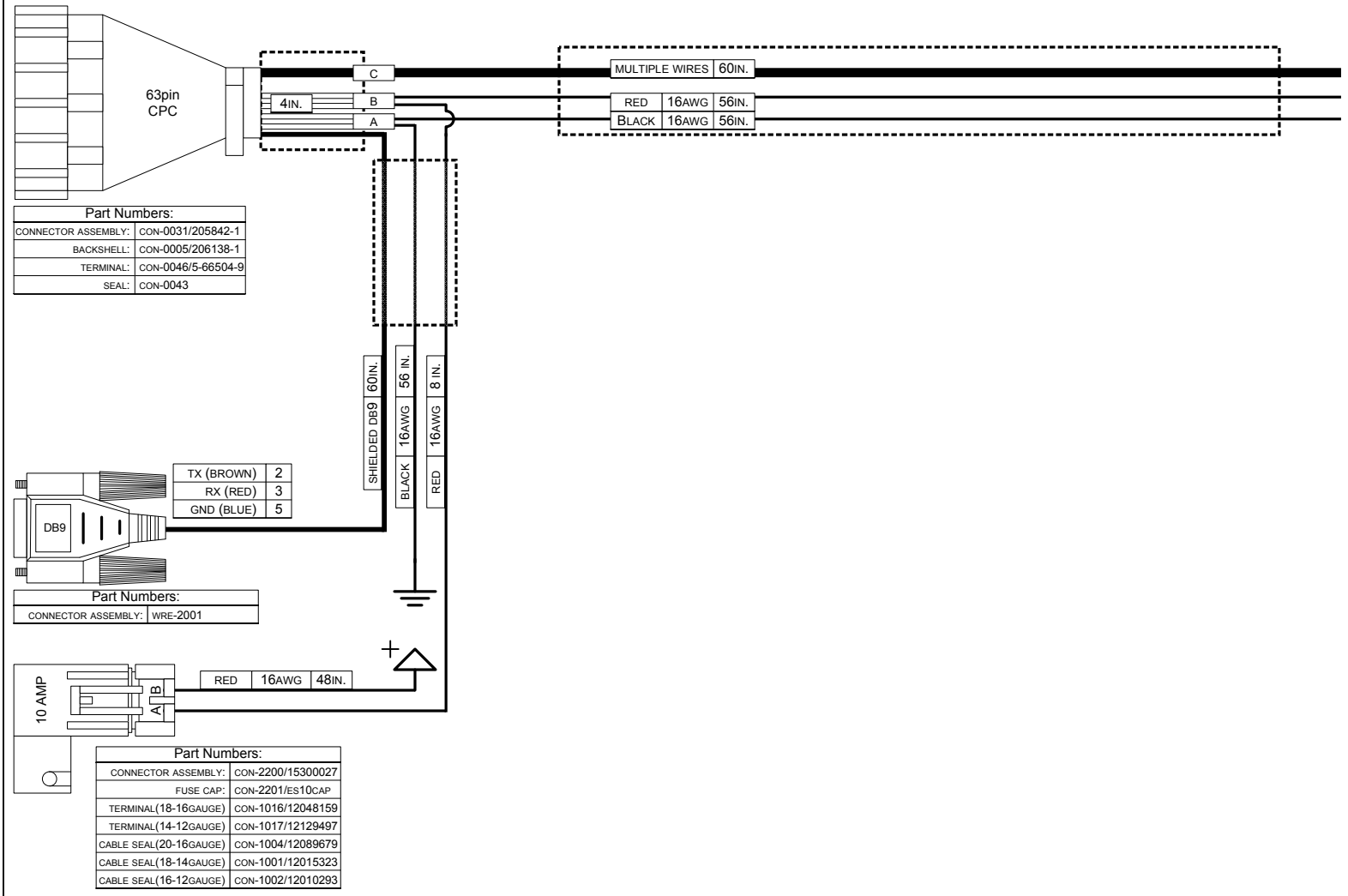
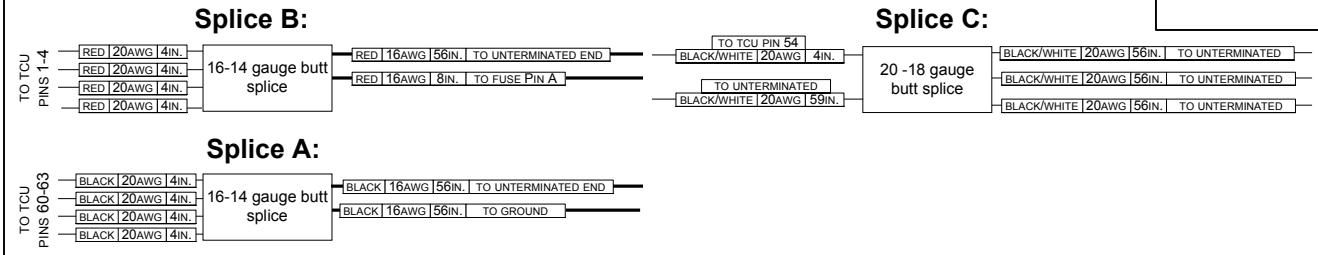

Pre - Populated Wires		
CPC	Wire	Color
5	Speed Input 1	orange/black
6	Speed Input 2	orange/red
7	Speed Input 3	orange/lt.green
9	Speed Output	orange/white
37	PWM Output 1	violet/black
28	PWM Output 2	violet/red
20	PWM Output 3	violet/lt.green
12	PWM Output 4	violet/lt.blue
52	PWM Output 5	violet/white
45	PWM Output 6	violet/orange
59	Digital Output 1 / PWM 7	pink/black
53	Digital Output 2 / PWM 8	pink/red
36	Digital Output 3 / PWM 9	pink/lt. green
44	Digital Output 4	pink/lt. blue
19	Digital Output 5	pink/white
28	Digital Output 6	pink/orange
46	Analog Input 1	yellow/black
47	Analog Input 2	yellow/red
48	Analog Input 3	yellow/lt.green
49	Analog Input 4	yellow/lt. blue
50	Analog Input 5	yellow/white
51	Analog Input 6	yellow/orange
13	Digital Input 1	gray/black
14	Digital Input 2	gray/red
15	Digital Input 3	gray/lt.green
16	Digital Input 4	gray/lt.blue
17	Digital Input 5	gray/white
18	Digital Input 6	gray/orange
21	Digital Input 7	gray/yellow
22	Digital Input 8	gray/pink
58	+5 V reference	red/white
1- 4	+12 V Power	16A WG Red
60 - 63	Gnd	16A WG Black
54	Sensor Ground	black/white
54	Sensor Ground	black/white
54	Sensor Ground	black/white
54	Sensor Ground	black/white

Powertrain Control Solutions, LLC.

11139 Air Park Rd. Suite 2
Ashland, VA 23005

www.ptcs.us

Phone: (804) 752-6025
Fax: (804) 752-3516

TITLE:

UNIVERSAL HARNESS

PART NUMBER: TCM-4000

DESCRIPTION:
UNIVERSAL HARNESS

DRAWN BY: J.Ballenger DATE: 5/10/2004 PAGE: 2 OF 2

REV.	DESCRIPTION	DATE	BY
0	ORIGINAL REVISION	5/10/04	JB
1	NEW FORMAT	5/23/05	RC
2	ADDED INPUT/OUTPUT WIRES	12/21/05	JT

CPC	Pin Function	Harness Function	Universal Harness	Colors
1	+12v	Battery Connection	Battery Connection	red
2	+12v	Battery Connection	Battery Connection	red
3	+12v	Battery Connection	Battery Connection	red
4	+12v	Battery Connection	Battery Connection	red
5	Speed Input 1	Engine Speed Input	Engine Speed Input	orange/black
6	Speed Input 2	Transmission Speed Input	Transmission Speed Input	orange/red
7	Speed Input 3	TCC Speed Input	TCC Speed Input	orange/lt. Green
8	Speed Input 4	Optional Speed Input	-	orange/lt. Blue
9	Speed Output	Speedometer Drive Output	Speedometer Drive Output	orange/white
10	unused	-	-	-
11	unused	-	-	-
12	PWM Out 4/freq2	PWM/Solenoid Driver	PWM/Solenoid Driver	violet/lt. Blue
13	Digital Input 1	Digital Input	Digital Input	gray/black
14	Digital Input 2	Digital Input	Digital Input	gray/red
15	Digital Input 3	Digital Input	Digital Input	gray/lt. Green
16	Digital Input 4	Digital Input	Digital Input	gray/lt. Blue
17	Digital Input 5	Digital Input	Digital Input	gray/white
18	Digital Input 6	Digital Input	Digital Input	gray/orange
19	Digital Out 5	Digital Driver	Digital Driver	pink/white
20	PWM Out 3/freq2	PWM/Solenoid Driver	PWM/Solenoid Driver	violet/lt. Green
21	Digital Input 7	Digital Input	Digital Input	gray/yellow
22	Digital Input 8	Digital Input	Digital Input	gray/pink
23	Digital Input 9	Digital Input	-	brown/black
24	Digital Input 10	Digital Input	-	brown/red
25	Digital Input 11	Digital Input	-	brown/lt. Green
26	Digital Input 12	Digital Input	-	brown/lt. Blue
27	Digital Out 6	Digital Driver	Digital Driver	pink/orange
28	PWM Out 2/freq1	PWM/Solenoid Driver	PWM/Solenoid Driver	violet/red
29	unused	-	-	-
30	RS-232 Transmit	Communications Cable	db9	white/orange
31	RS-232 Receive	Communications Cable	db9	white/lt. Blue
32	CAN/RS-232 GND	Communications Cable	db9	white/lt. Green
33	CAN High	Communications Cable	-	white/red
34	CAN Low	Communications Cable	-	white/black
35	unused	-	-	-
36	Digital Out 3 / PWM 9	Digital Driver	Digital Driver	pink/lt. Green
37	PWM Out 1/freq 1	PWM/Solenoid Driver	PWM/Solenoid Driver	violet/black
38	unused	-	-	-
39	Digital Input 13	Digital Input	-	brown/white
40	Digital Input 14	Digital Input	-	brown/orange
41	Digital Input 15	Digital Input	-	brown/yellow
42	Digital Input 16	Digital Input	-	brown/pink
43	unused	-	-	-
44	Digital Out 4	Digital Driver	Digital Driver	pink/lt. Blue
45	PWM Out 6/freq1	PWM/Solenoid Driver	PWM/Solenoid Driver	violet/orange
46	Analog Input 1	Analog Input	Analog Input	yellow/black
47	Analog Input 2	Analog Input	Analog Input	yellow/red
48	Analog Input 3	Analog Input	Analog Input	yellow/lt. Green
49	Analog Input 4	Analog Input	Analog Input	yellow/lt. Blue
50	Analog Input 5/temp	Analog Input	Analog Input	yellow/white
51	Analog Input 6/temp	Analog Input	Analog Input	yellow/orange
52	Pwm Out 5/freq1	PWM/Solenoid Driver	PWM/Solenoid Driver	violet/white
53	Digital Out 2 / PWM 8	Digital Driver	Digital Driver	pink/red
54	Sensor/AD Gnd	Sensor or reference Gnd	Sensor or reference Gnd	black/white
55	unused	-	-	-
56	unused	-	-	-
57	unused	-	-	-
58	Ref Voltage (+5v Sensor Output)	Sensor/reference Voltage	Sensor/reference Voltage	red/white
59	Digital Out 1/ PWM 7	Digital Driver	Digital Driver	pink/black
60	Gnd	Battery Connection	Battery Connection	black
61	Gnd	Battery Connection	Battery Connection	black
62	Gnd	Battery Connection	Battery Connection	black
63	Gnd	Battery Connection	Battery Connection	black

	db9 pinout	DB9
1	none	none
2	transmit	brown
3	receive	red
4	none	none
5	gnd	blue
6	none	none
7	none	none
8	none	none
9	none	none

Extra Wires List	
1	orange/lt. Blue
2	brown/black
3	brown/red
4	brown/lt. Green
5	brown/lt. Blue
6	brown/white
7	brown/orange
8	brown/yellow
9	brown/pink
10	white/red
11	white/black

**Note: This view is looking at the rear of the connector where the pins are inserted.
Please reference the connector before assembly as the pins are numbered on the
connector as well**

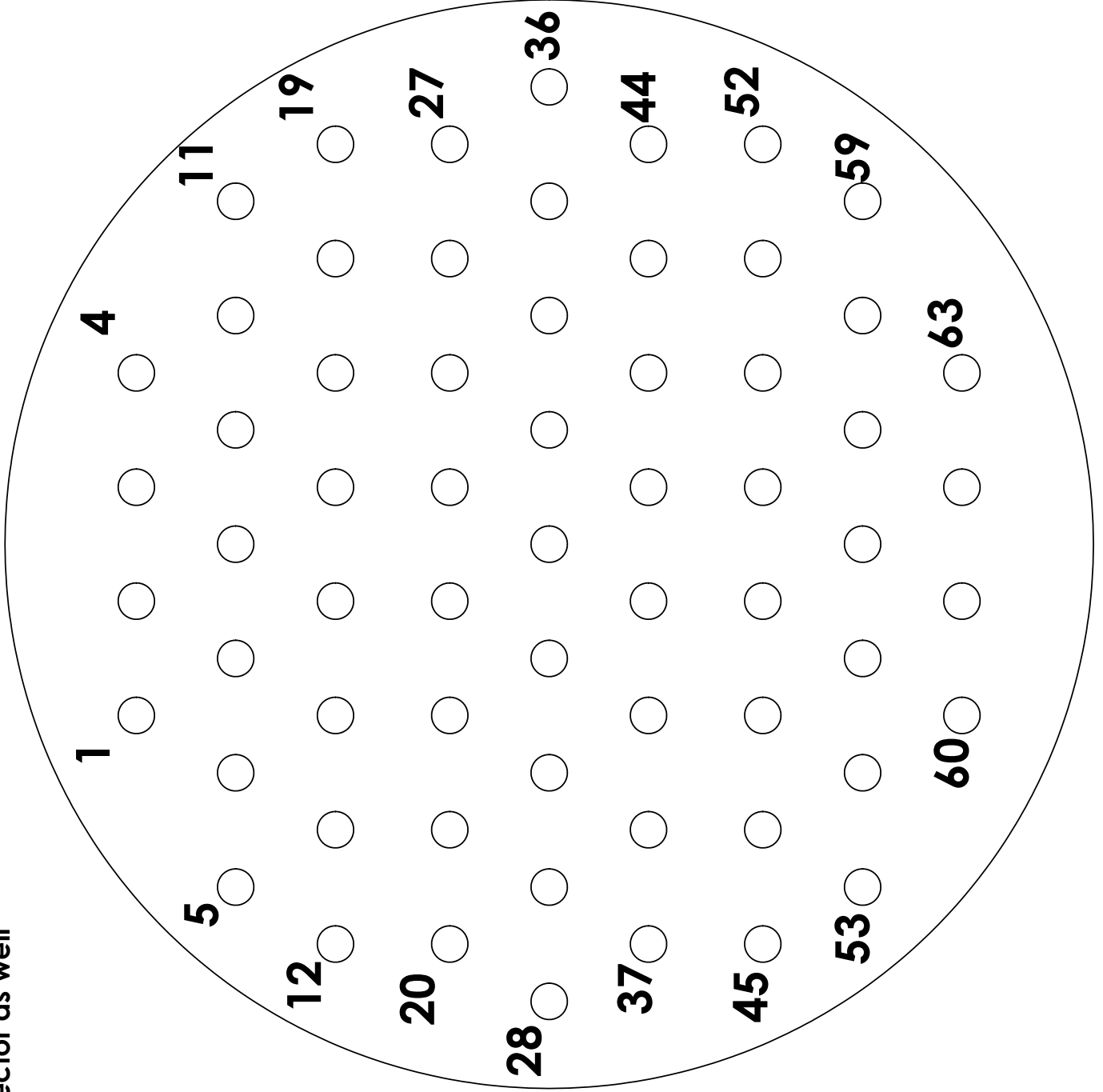

9. Backshell Removal Instructions



1. Attach the 63pin Circular plastic connector (CPC) to the TCU.



2. Remove any tape on the corrugated loom near the CPC.



3. Remove the two screws securing the cable clamp.

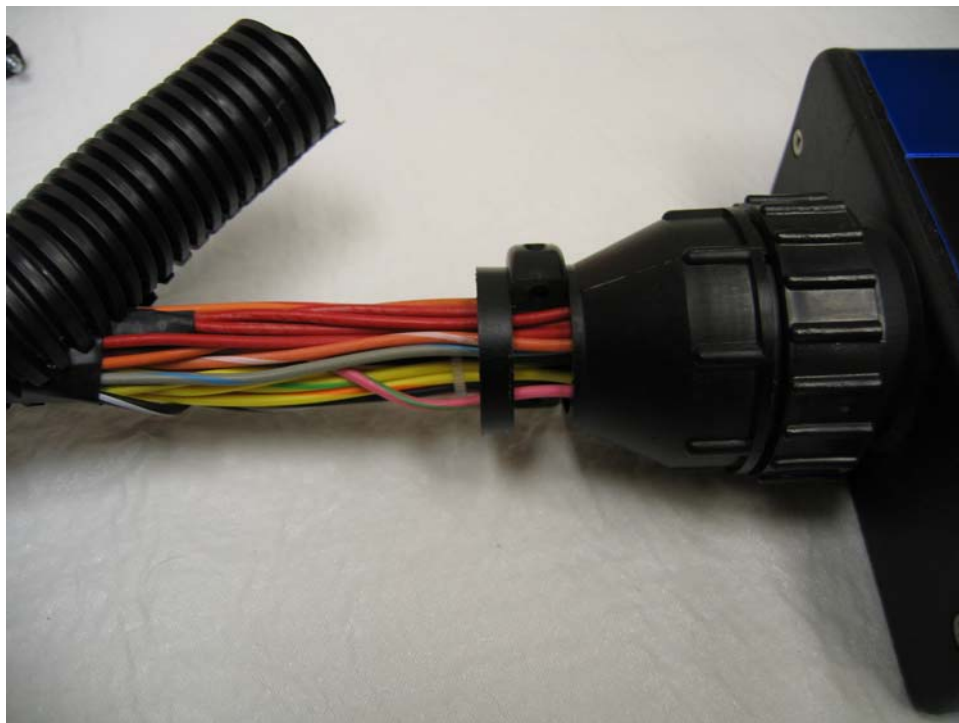

4. Pull the corrugated loom away from the wires several inches away from the CPC.



5. Rotate the cable clamp counter-clockwise (left) to unscrew the cable clamp from the CPC.



6. Pull the cable clamp several inches away from the CPC and wire entry seal.

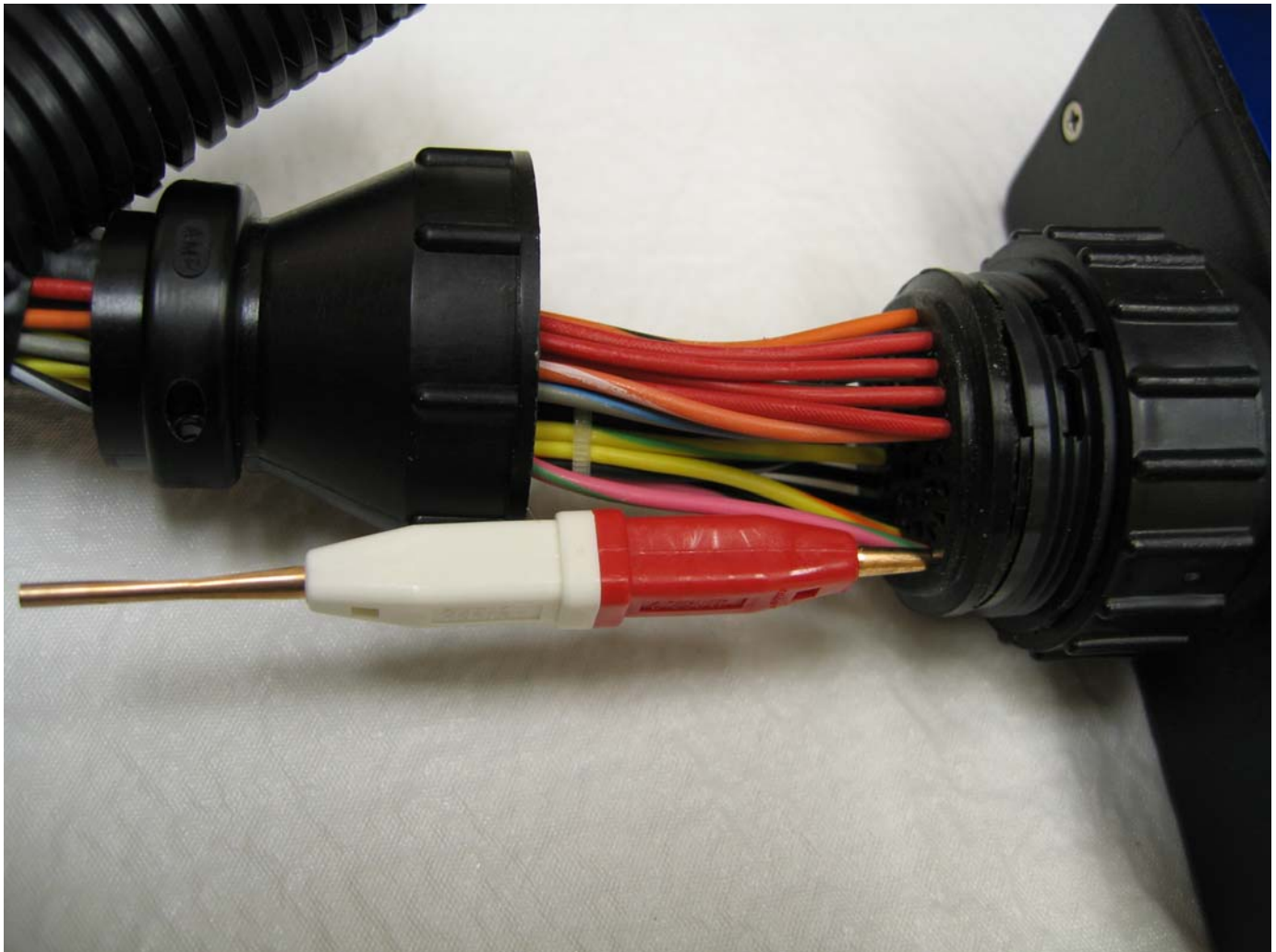

7. To remove a wire/terminal, insert the insertion/extraction tool. You may need to purchase this from your dealer/reseller. Cheap imitation (often poor in quality) parts can be found at a local electronics store as an insertion/extraction tool for D-Sub terminals. The insertion/extraction tool must pass the seal and enter the terminal. Once fully inserted, the tool should look like the image above. If you have trouble inserting the insertion/extraction tool, do not force it forwards. Too much force can damage the tool and the connector. Instead, try to rotate the tool and continue to move the tool around in the circular terminal hole. Keep trying this procedure until you are able to properly insert the tool.

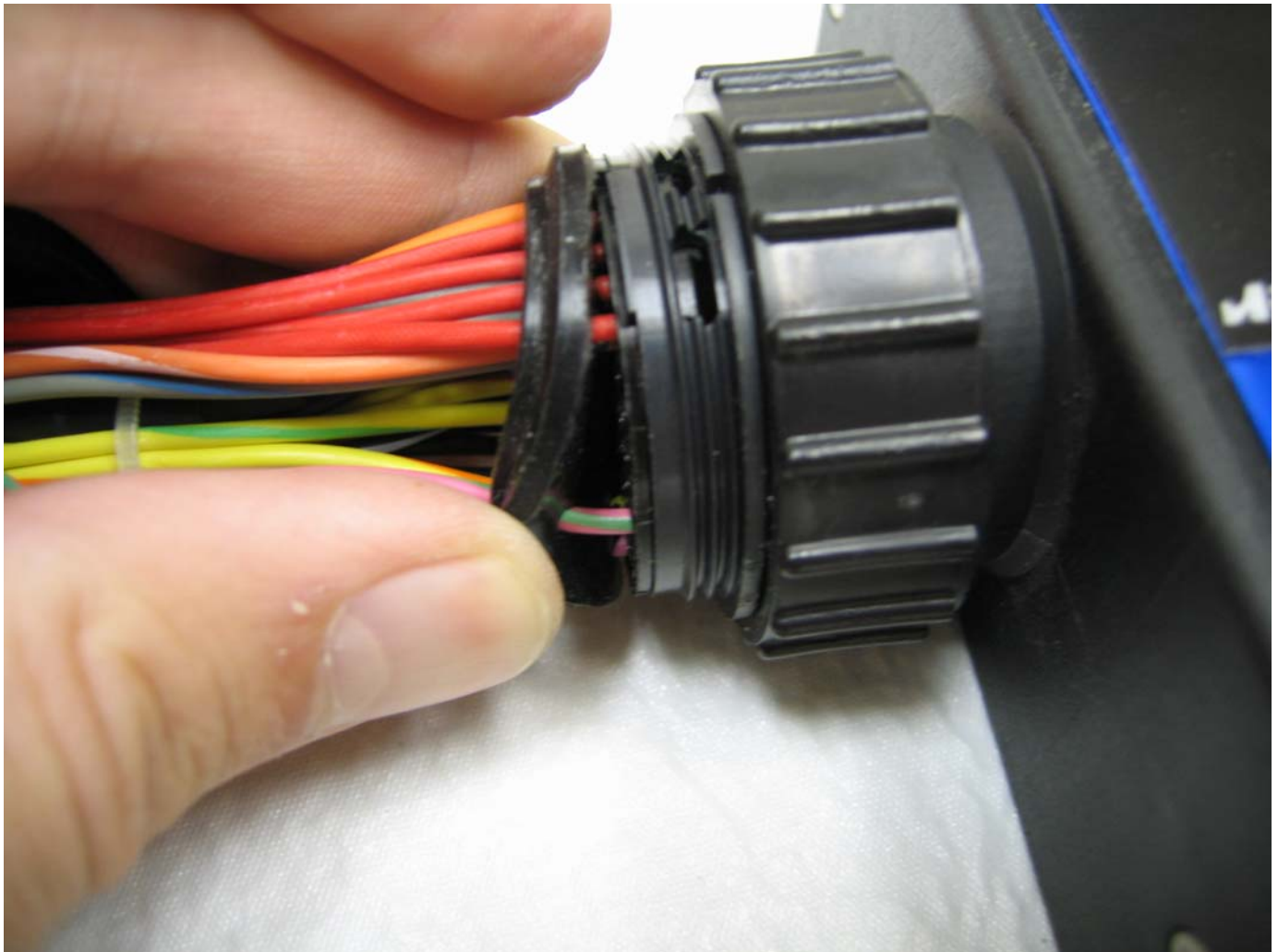

8. The wire entry seal is a rubber seal that fits behind the CPC to protect the terminals from weather. When inserting a wire, it may be necessary to pierce the connector first and then verify the position of the terminal hole in the CPC.

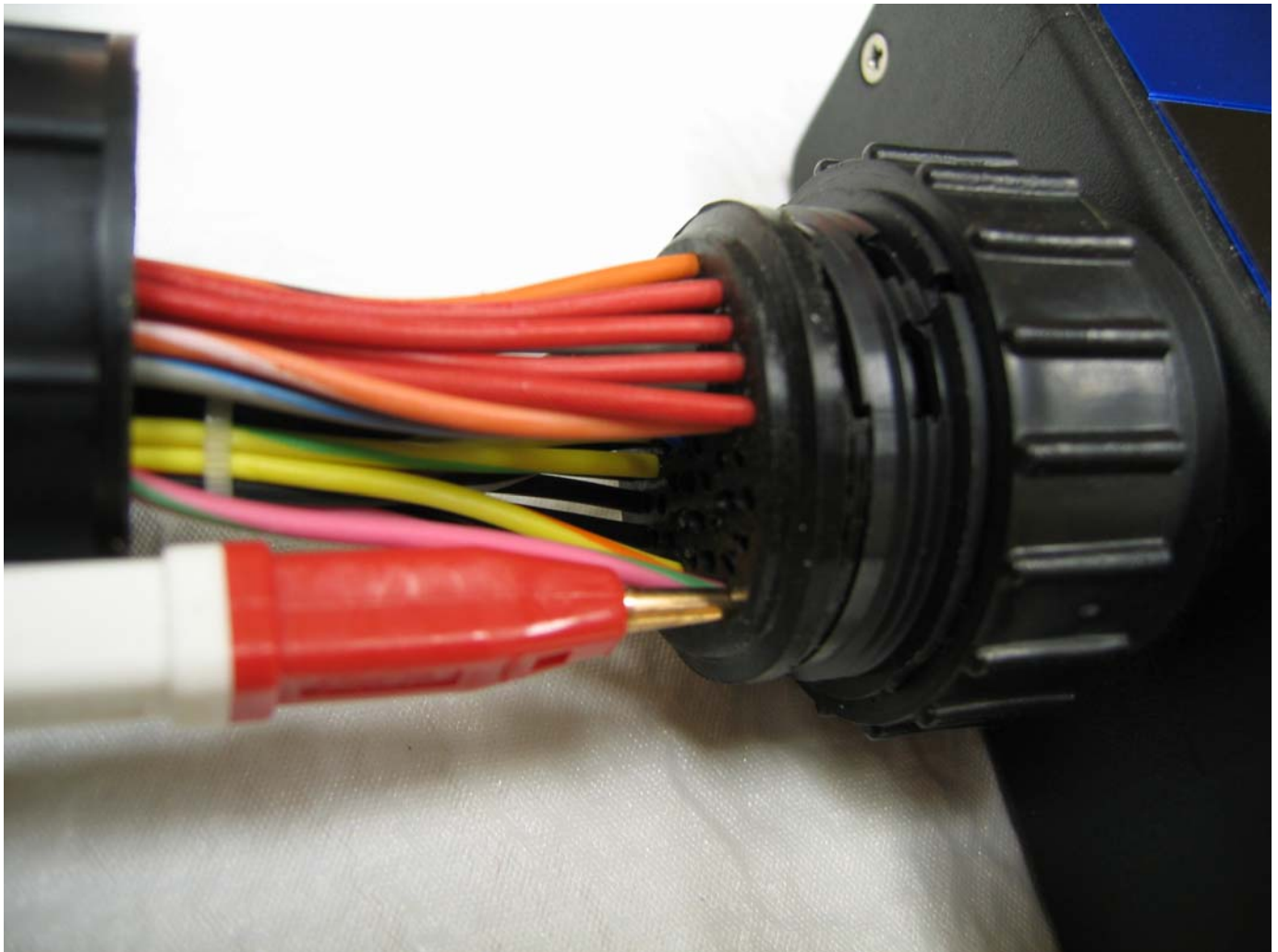

9. Here is a closer view of the insertion/extraction tool in its fully inserted position.

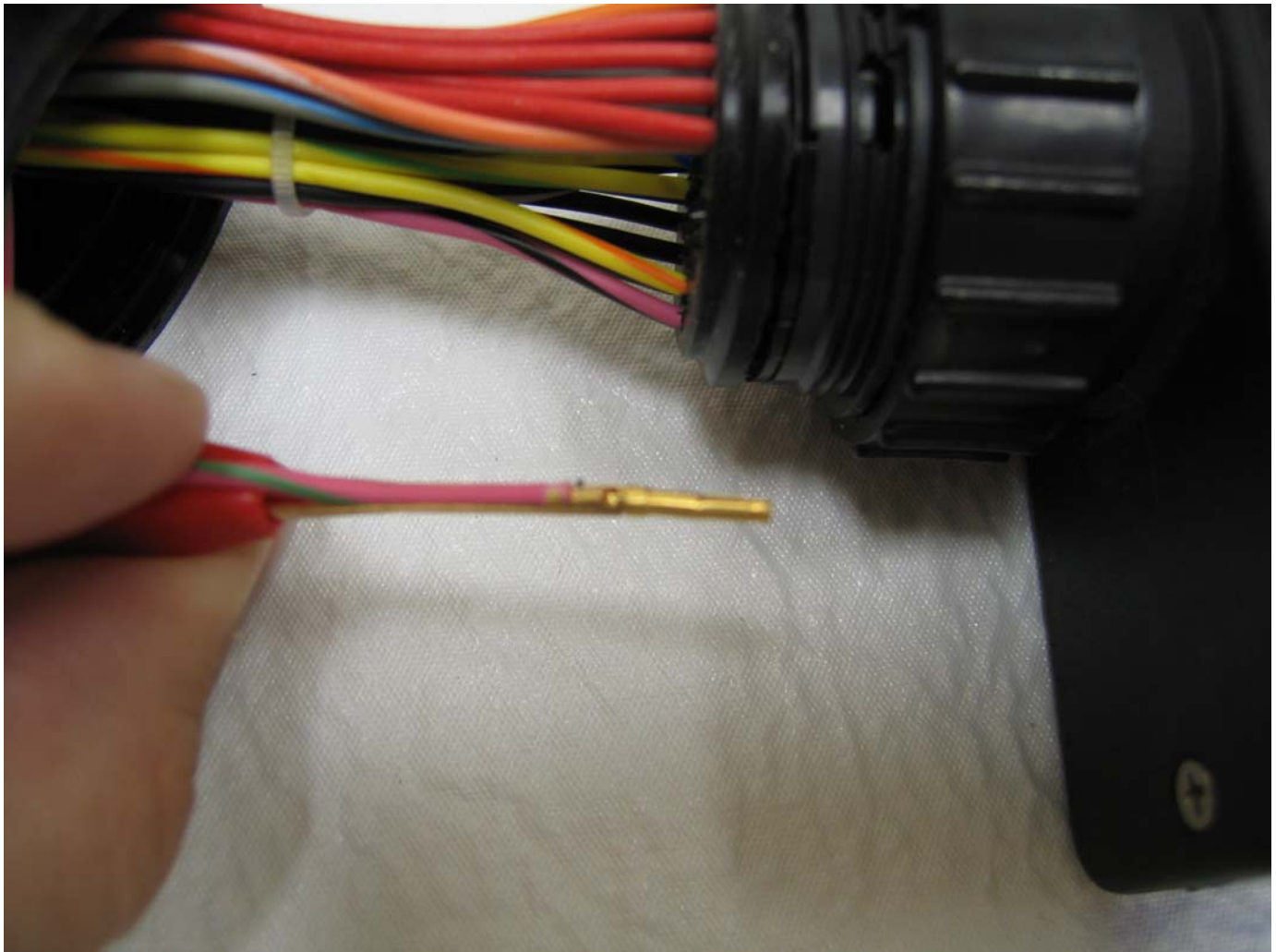

10. To add a wire, you must first terminate the proper female terminal on an appropriately sized automotive grade wire (20 gauge TXL). This wire should be first routed through the center of the backshell. Once this is done, you should also verify the pin position according to the numbers on the back of the CPC (just below the wire entry seal) and/or with the CPC pinout chart in this manual.

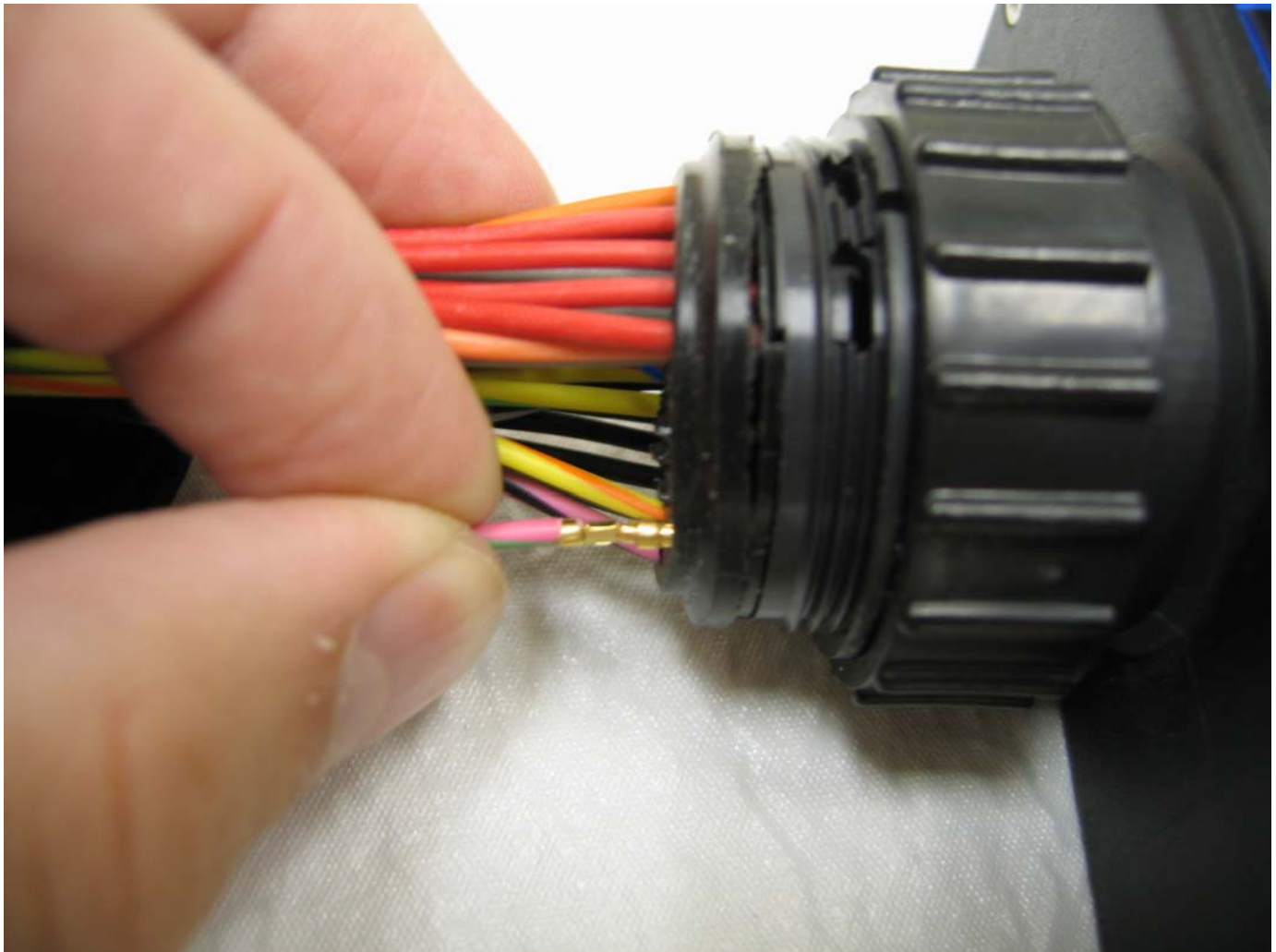

11. Once the appropriate position has been verified for the terminal and wire, the terminal may be inserted through the wire entry seal. This can be done with the insertion/extraction tool as shown in step 9 or without the insertion/extraction tool as shown above. Be extremely careful to avoid bending the terminal as this will destroy the terminal and possibly damage the connector.
12. Re-assembly is the reverse of dis-assembly.

10. Glossary of Terms

Absolute Pressure:	Atmospheric (barometric) pressure plus the gauge reading.
Accumulator:	A component of the transmission that absorbs hydraulic pressure during the apply of clutch or band. Accumulators are designed to control the quality of a shift from one gear to another by cushioning the shock of hydraulic oil pressure being applied to clutch or band.
Active High:	State when device is on or engaged by the application of +12v or power.
Active Low:	State when device is on or engaged by the application of electrical ground.
Ampere (amp):	A unit of measure for the flow of electrical current in a circuit.
Analog:	Data which is represented by continuous variation.
Atmospheric Pressure:	The force exerted on everything around us by the weight of air. At sea level, atmospheric pressure is 14.7psi (pounds per square inch), or in the metric system, 101.3 kPa (kilopascals) or 1 bar.
Band:	A flexible ring of steel with an inner lining of friction material. When tightened around the outside of a drum, a planetary member is held stationary to the transmission case.
Brake Switch:	An electrical device that provides signals to the transmission control unit (TCU) based on the position of the brake pedal. The TCU uses this information to apply or release the torque converter (TCC).
Boost:	When intake manifold pressure is greater than atmospheric pressure due to turbo or supercharging.
Converter:	(See torque converter)
Converter Lockup:	The switching from hydro-mechanical to direct mechanical drive, usually through the application of a friction element called the converter clutch.
Coolant Temperature (CLT):	A resistance based sensor that measures engine coolant temperature. The calibrated resistance changes with temperature Sensor and can be measured by the TCU.

Crank Sensor:	A speed sensor for engine speed often located on the crankshaft.
Current:	The flow (or rate) of electrons moving through a circuit. Current is measured in amperes (amp).
Differential:	Located within the final drive unit, the differential provides power to the driven wheels.
Downshift:	A change in a gear ratio where engine speed and wheel torque increases.
Duty Cycle:	In reference to an electrical signal, often an electronically controlled solenoid. It is the amount of time (expressed as a percentage) that current flows through the solenoid. The percentage of time that a pulsewidth modulated output is turned on. A duty cycle of 100% indicates a fully turned-on modulation output.
Diode:	A solid-state device that permits current to flow in one direction only. It performs as a one-way check valve.
Digital:	Logic that can only be expressed in two states; ON or OFF.
ECU:	See engine controller.
Engine Braking:	A condition where compression from the engine is used to decrease vehicle speed.
Engine controller:	An electronic control unit used to process several inputs for the control of several outputs relating to the engine.
Fail-Safe Mode:	A condition whereby a component (i.e. engine or transmission) will partially function even if its electrical system is disabled. A substitute value may be used by the TCU to replace a faulty signal from an input sensor. The temporary value allows the vehicle to continue to be operated with limited functionality.
Final Drive:	An essential part of the axle drive assembly where final gear reduction takes place in the Powertrain. In RWD applications and north-south FWD applications, it must also change the power flow direction to the axle shaft by ninety degrees.
Fluid:	In hydraulics, a liquid is used for transmitting force or motion. In this manual fluid refers primarily to transmission fluid.
Fluid Pressure:	A pressure that is consistent throughout a given fluid circuit.

Fluid viscosity:	The resistance of a liquid to flow. A cold fluid (oil) has greater viscosity and flows more slowly than hot fluid (oil).
Freewheeling:	There is a power input with no transmission of power output. The power flow is ineffective.
Friction:	The resistance that occurs between contacting surfaces. This relationship is expressed by a ratio called the coefficient of friction (μ).
Friction, coefficient of:	The amount of surface tension between two contacting surfaces; expressed by a scientifically calculated number.
Friction modifier:	Changes the coefficient of friction of the fluid between the mating steel and composition clutch/band surfaces during the engagement process and allows for a certain amount of intentional slipping for a good “shift-feel.”
Fuse:	A device consisting of a piece of wire with a low melting point, inserted in a circuit. It will melt and open the circuit when the system is overloaded.
Fusible link:	A device to protect the main chassis wiring harness if a short circuit occurs in the unfused part of the wiring. The link is a short piece of copper wire approximately four inches long inserted in series with the circuit; it acts as a fuse. The link is four gauges smaller in size than the circuit wire it is protecting.
Gear:	A toothed mechanical device that acts as a rotating lever to transmit power or turning effort from one shaft to another (see gear ratio).
Gear Hunting:	Repeated quick series of upshifts and downshifts that cause’s noticeable change in rpm.
Gear Range:	A specific speed to torque ratio at which the transmission is operating (i.e. 1 st gear, 2 nd gear, etc.).
Gear Ratio:	The number of revolutions the input gear makes to one revolution of the output gear. In a simple gear combination, two revolutions of the input gear to one of the output gear gives a ratio of 2:1.
Gear reduction:	Torque is multiplied and speed decreased by the factor of the gear ratio. For example, a 3:1 gear ratio changes an input torque of 180 lb-ft and an input speed of 2700rpm to 540 lb-ft and 900rpm respectively. (No account is taken of frictional losses, which are always present.
Ground:	In this manual, ground primarily refers to electrical ground. A connection to the negative side of vehicle battery. A connection to engine ground or

transmission ground should also form a connection to the negative side of vehicle battery.

- Horsepower (HP):** A measurement of the rate at which a device can perform work. $HP = (\text{Torque} * \text{RPM}) / 5252$ or $HP = 550 \text{ lb-ft per second}$.
- Hydraulic Circuit:** A fluid passage which often includes the mechanical components in that circuit designed to perform a specific function.
- Hertz (Hz):** The international unit of frequency equal to one cycle per second. (10,000 Hertz equals 10,000 cycles per second).
- Line Pressure:** The main fluid pressure in a hydraulic system created by the pump and pressure regulator valve.
- Load:** The amount of work that an engine must provide at a given instant. Load is measured by using a TPS, MAP or MAF sensor.
- Manifold Absolute Pressure (MAP) Sensor:** A device that measures the absolute pressure (or vacuum) of the intake charge for an engine. This signal can be interpreted as **MAP Sensor:** engine load.
- Mass Airflow (MAF) Sensor:** A device that measures the airflow into the engine based on air mass. This signal can be interpreted as engine load.
- Millisecond (ms):** A length of time equal to one one-thousandth of a second. 1 millisecond = 0.001 second.
- Orifice:** A restricting device (usually a hole in the spacer plate) for controlling pressure build up into another circuit.
- Overdrive:** An operating condition in the gear set allowing output speed to be higher than the input speed and output torque to be lower than the input torque.
- Pressure:** A measurable force that is exerted on an area and expressed as kilopascals (kPa), pounds per square inch (psi) or bar.
- Power:** In this manual, power primarily refers to a 12 volt source. Also a connection to the positive side of vehicle battery or a switched 12 volt source.
- Pressure Switch Assembly (PSA):** Mounted inside the transmission, it is a grouping of oil pressure switches that sends values to the TCU when certain hydraulic passages are charged with oil pressure.
- Pulsewidth:** An electronic signal that continuously cycles the ON and OFF time

Modulated (PWM):	of a device (such as a solenoid) while varying the amount of ON time.
Pulsewidth Modulated Solenoid:	A computer-controlled solenoid that turns on and off at a variable rate producing a modulated oil pressure. Employed in many (PWM) electronic automatic transmissions and transaxles, these solenoids are used to manage shift control and converter clutch hydraulic circuits.
Range Switch:	This is a mechanical logic device that converts the position of the vehicle's gear select lever into electrical digital logic. This switch tells the computer what gear or lever position the driver has chosen.
Reduction (Gear Reduction):	An operating condition in the gear set allowing output speed to be lower than input speed and output torque to be higher than input torque.
Resistance:	The property of an electrical circuit that tends to prevent or reduce the flow of current. Resistance is measured in ohms. A resistor is a device installed in an electrical circuit to permit a predetermined current to flow with a given applied voltage.
Solenoid:	An electromagnetic device containing a coil winding and a movable core. As current is sent through the winding, the core is moved. When applied to hydraulic oil circuits, pressure in that circuit can be controlled electrically. In this manual, solenoid primarily refers to electronically controlled solenoids. Solenoids may be PWM or digitally controlled. PWM solenoids typically regulate pressure while digital solenoids typically regulate flow.
Slipping:	Noticeable increase in engine rpm without a corresponding increase in vehicle speed; usually occurs during or after initial clutch or band engagement.
Stall Speed:	In fluid drive transmission applications, stall speed refers to the maximum engine rpm with the transmission engaged and vehicle stationary, when the throttle valve is wide open.
Switch:	A device used to open, close, or redirect the current in an electrical circuit.
Thermistor:	A special resistor used to measure fluid temperature; it decreases its resistance with increases in temperature.
Throttle Position Sensor (TPS):	A sensor that measures the relative travel of the throttle plate.

Torque:	A measurable twisting force expressed in terms of Newton-meters (N*m), pound feet (lb-ft), or pound inches (lb-in).
Torque Converter (TCC):	A component of an automatic transmission, (attached to the engine flywheel) that transfers torque from the engine to the transmission through a fluid coupling. The torque converter also has the ability to provide some torque multiplication.
Transaxle:	A transmission and final drive unit combined into a single unit; may be designed in a longitudinal or transverse configuration for either front, rear or all wheel drive vehicles.
Transmission:	A Powertrain component designed to transmit torque and speed developed by the engine. Also provides direct drive, reverse and neutral.
Transmission Fluid Temperature Sensor (TFT):	A resistance based sensor that measures transmission fluid temperature. The calibrated resistance changes with temperature Sensor and can be measured by the TCU.
Upshift:	A change in a gear ratio where engine speed and wheel torque decreases.
Vehicle Speed Sensor (VSS):	A device that measures driveshaft speed by counting the number of teeth passing by on a nearby wheel. This count can be calculated to determine vehicle speed if the final drive ratio and gear ratios are known.

11. Full Transmission Controller Specifications

11.1 Outputs

Pulsewidth Modulated (PWM) Drivers

- 6 x 3.5 amp programmable active high or low drivers
- 3 drivers programmable for Digital or PWM
- Stepper motor programmable
- Short circuit protection
- Over current protection
- Thermal shutdown
- Fully programmable frequency and duty cycle
- Built-in failure diagnostics

Digital Drivers

- 6 x 3.5 amp programmable active high or low drivers
- 3 drivers programmable for Digital or PWM
- Stepper motor programmable
- Short circuit protection
- Over current protection
- Thermal shutdown
- Built-in failure diagnostics

Speed Output

- 1 pc programmable frequency output
- 1 driver usable as frequency output for high power speedometers
- Short circuit protection
- 20mA current limit
- +/- 10 volt output
- Compatible as a speedometer drive or speed sensor replacement

11.2 Inputs

Analog Inputs

- 6 x 0-5 volt programmable inputs
- Emi protected
- Built-in noise filtering
- 10 bit resolution
- Overvoltage protection
- Built-in failure diagnostics
- Resistors for direct measurement of resistance sensors on inputs 5&6

Digital Inputs

- 16 x programmable active high or low inputs
- Emi protected
- Built-in noise filtering
- Built-in failure diagnostics
- Overvoltage protection

Speed Inputs

- 4 x programmable frequency input
- User programmable high-pass filters and trigger levels
- Emi protected
- Overvoltage protection
- Compatible with magnetic, hall-effect and logic-level inputs

11.3 Communication

Controller Area Network (CAN)

- Noise tolerant, high speed communication standard typical in automotive applications
- 1Mb/s maximum transfer rate
- Meets 2.0b specifications
- User definable configuration and messages

RS-232

- Noise tolerant, low speed PC compatible communication standard
- 38.4 Kbps maximum transfer rate
- Used for datalogging & PC communication

11.4 Operating Conditions

- -40 to 105°C ambient temperature range
- 8 to 27 volt operating voltage
- 0.5 amp maximum operating current (controller only)

11.5 General

- Reverse battery protection
- Transient voltage (voltage spike) protection
- 1.2 lb weight
- 5.9 in x 4.15in x 1.75in
- 25 MHz military qualified microcontroller
- 1 year warranty (parts and labor)
- Rigorous factory testing procedure
- Burned in at factory
- In-field flash upgradeable
- Environmentally sealed circular connector rated to IP65 standard for water and dust ingress.
- Environmentally sealed case rated to IP65 standard for water and dust ingress.
- All materials rated for a high temperature, caustic and humid environment subject to automotive fluids.
- Durable anodized aluminum and high strength plastic case.
- Manufactured to IPC-A-610 Class3 (military) standards
- Manufactured in an ISO-9002 certified facility

12. Terms and Conditions

DEFINITIONS

“Products” means the products in PCS’s then-current Product List. A Product may include both hardware and software components. PCS may add to, delete from, or otherwise modify the Products on the Product List at any time.

“Customer” means an end user of a Product.

“Limited Warranty Statement” means PCS’s then-current warranty from PCS to Customers.

ORDERING AND PAYMENT

1. **ORDERS.** Orders shall be in writing and be subject to acceptance by PCS. The terms and conditions of each order shall be as provided by this Agreement, and the provisions of either party’s form of purchase order, acknowledgment or other business forms will not apply to any order notwithstanding the other party’s acknowledgment or acceptance of such form.
2. **SHIPMENT.** Shipment will be F.O.B. PCS’s specified warehouse (“Delivery Point”), freight collect, at which time title (excluding any software components of Products) and risk of loss will pass to Customer. All freight, insurance and other shipping expenses from Delivery Point, as well as any expenses related to Customer’s special packing requests, will be borne by Customer unless otherwise agreed to in writing by PCS.
3. **PAYMENT.** Subject to compliance with PCS’s credit requirements, payments on orders will be due and payable in full thirty (30) days from the invoice date. If Customer is in default of its payment obligations, PCS shall give written notice of such default to Customer. Upon receipt of such default notice, Customer shall have fifteen (15) days to cure. If Customer fails to cure within the fifteen (15) days notice period, Customer shall pay monthly service charges of 2% per month for any past due amounts. Customer shall have ninety (90) days from receipt of such default notice to cure. If Customer fails to cure within the (90) days notice period, Customer’s unpaid balance shall be referred to a collection agency. PCS may in its sole discretion change Customer’s credit terms and/or require C.O.D./prepayment for any shipments.
4. **FUNDS.** ALL payment for Products and Services by Customer and by Customer’s customers shall be made in **U.S. Funds** via check or other mutually agreed upon electronic payment methods. Local currency prices may vary between time of order and time of payment based on fluctuations in the currency exchange rate.
5. **TAXATION.** The payment obligations stated in this section are exclusive of any federal, state, municipal or other governmental taxes, duties, excise taxes or tariffs now or hereafter imposed on the sale of the Products. Any such taxes applied will be added to and itemized on PCS’s invoices when they are rendered.

WARRANTY

1. EXPRESS DISCLAIMER. PCS MAKES NO WARRANTIES OR REPRESENTATIONS AS TO THE Products, EXCEPT AS SET FORTH BELOW. ALL IMPLIED WARRANTIES AND CONDITIONS, INCLUDING BUT NOT LIMITED TO IMPLIED WARRANTIES OF MERCHANTABILITY, FITNESS FOR A PARTICULAR PURPOSE AND NONINFRINGEMENT, ARE HEREBY DISCLAIMED.
2. LIMITATION OF LIABILITY. THE LIABILITY OF PCS AND ITS SUPPLIERS ARISING OUT OF OR RELATING TO THIS MANUAL OR THE SUPPLY OF Products HEREUNDER, SHALL BE LIMITED TO THE ACTUAL AMOUNTS PAID BY CUSTOMER TO PCS FOR THE Products GIVING RISE TO SUCH DAMAGES, AND SHALL IN NO EVENT INCLUDE LOSS OF PROFITS, COST OF PROCURING SUBSTITUTE GOODS OR SERVICES, OR ANY INCIDENTAL, INDIRECT OR CONSEQUENTIAL DAMAGES OF ANY KIND, EVEN IF PCS OR ITS SUPPLIER IS AWARE OF THE POSSIBILITY OF SUCH DAMAGES.
3. LIMITED WARRANTY STATEMENT. Powertrain Control Solutions, LLC. warrants all merchandise against defects in factory workmanship and materials for a period of 12 months after purchase. This warranty applies to the first retail purchaser and covers only those products exposed to normal use or service. Provisions of this warranty shall not apply to a Powertrain Control Solutions, LLC. product used for a purpose for which it is not designed, or which has been altered in any way that would be detrimental to the performance or life of the product, or misapplication, misuse, negligence or accident. On any part or product found to be defective after examination by Powertrain Control Solutions, LLC., Powertrain Control Solutions, LLC. will only repair or replace the merchandise through the original selling dealer or on a direct basis. Powertrain Control Solutions, LLC. assumes no responsibility for diagnosis, removal and/or installation labor, loss of vehicle use, loss of time, inconvenience or any other consequential expenses. The warranties herein are in lieu of any other expressed or implied warranties, including any implied warranty of merchantability or fitness, and any other obligation on the part of Powertrain Control Solutions, LLC., or selling dealer.

13. Index

Accumulator Pressure	13, 24, 27, 28, 29, 34, 42, 44, 55
Analog	10, 11, 15, 21, 22, 23, 33, 34, 37, 38, 39, 40, 41, 42, 43, 44, 48, 49, 52, 53, 54, 56, 71, 78
Analog Input	10, 11, 15, 21, 22, 23, 33, 37, 38, 39, 40, 41, 42, 43, 44, 48, 53, 56, 78
CAN	14, 19, 58, 78
Communication	14, 16, 18, 19, 20, 21, 37, 58, 78
Datalog	26, 34, 35, 36, 59
Diagnostic Trouble Codes	37
Digital	9, 10, 12, 13, 14, 23, 24, 25, 34, 45, 48, 49, 50, 52, 53, 54, 72, 75, 77, 78
Digital Input	9, 10, 14, 23, 34, 45, 48, 49, 50, 78
Digital Output	12, 13, 14, 24, 25, 45, 52, 53
Downshift	15, 29, 30, 31, 33, 34, 38, 43, 44, 45, 49, 53, 56, 72
Dyno	34, 49, 53, 55
File	18, 19, 20, 21, 35, 36, 59
Flash Upgrade	36, 37, 79
Forum	13, 16, 24, 27
Horn	45, 53, 56
Hotkeys	36, 59
Inputs	5, 6, 7, 9, 10, 11, 13, 17, 18, 21, 22, 23, 25, 27, 34, 37, 39, 40, 45, 48, 49, 50, 51, 58, 72, 78
Line Pressure	13, 24, 27, 28, 29, 33, 34, 42, 43, 44, 55, 74
Location	13, 14, 15, 19, 23, 24, 35, 44
Manual Mode	9, 10, 12, 14, 15, 21, 23, 25, 34, 38, 40, 45, 46, 47, 48, 49
Monitor	8, 16, 22, 35, 37, 38, 59
Monitor Screen	16, 22, 35, 37, 38
Offline	20, 21, 59
Online	13, 20, 21, 24, 35, 36, 37, 59
Outputs	6, 12, 13, 17, 18, 21, 23, 24, 25, 34, 40, 52, 54, 56, 57, 72, 77
Password Protection	37
Program	6, 13, 17, 20, 33, 35, 57
PWM	7, 12, 13, 24, 31, 34, 52, 53, 54, 55, 56, 57, 75, 77
PWM Output	12, 13, 24, 54
PWM Shift Solenoid	34, 57
Shift	4, 5, 6, 7, 12, 13, 14, 17, 18, 23, 24, 26, 27, 28, 29, 30, 33, 34, 41, 48, 49, 50, 54, 56, 57, 71, 73, 75
Solenoid	6, 7, 8, 12, 13, 18, 21, 23, 24, 27, 28, 34, 52, 54, 55, 56, 57, 72, 75
Specifications	77, 78
Speed4	5, 7, 8, 9, 11, 12, 13, 15, 17, 18, 25, 26, 27, 28, 29, 30, 32, 33, 34, 41, 49, 50, 51, 52, 53, 55, 57, 72, 73, 74, 75, 76, 77, 78
Support	16, 20, 21, 23, 27, 36, 37, 58
TCC	9, 11, 12, 13, 18, 23, 24, 25, 30, 31, 32, 34, 49, 51, 52, 53, 55, 56, 57, 71, 76
TCC Lockup	23, 32, 34, 44, 52, 53, 55, 56
TCC Pressure	31, 34, 55
TCC/Wheel Slip	33, 34, 57
Temperature	5, 8, 10, 11, 14, 21, 22, 23, 33, 34, 37, 39, 40, 43, 55, 57, 71, 75, 76, 79
Test Mode	34, 38
Throttle Position Sensor	10, 15, 21, 22, 27, 28, 29, 33, 38, 40, 41, 49, 57, 58, 74, 75
Tire Diameter	11, 12, 25, 39, 51
Traction Control	5
Trim Solenoid	57
Units Selection	39
Upgrade	36, 37
Upshift	15, 29, 30, 31, 33, 34, 38, 43, 44, 45, 48, 49, 53, 56, 76
Vehicle Speed Sensor	8, 26, 57, 58, 76
Voltage	15, 22, 23, 26, 33, 37, 41, 42, 43, 45, 54, 75, 79
Warranty	79, 80, 81
Website	6, 16, 18, 19, 27
Wire	6, 7, 9, 10, 11, 12, 14, 15, 21, 22, 23, 25, 38, 40, 41, 45, 48, 49, 60, 65, 66, 67, 69, 70, 73