

| BOM # | DESCRIPTION                           | PCS PART # | QTY |
|-------|---------------------------------------|------------|-----|
| 1     | 1/2" SPACER, 4LHD FIXED FLANGE OUTPUT | BRK0240    | 1   |
| 2     | 7/16-14 X 1.25" FLANGED HEX BOLT      | TRN7531    | 4   |

**NOTES:**

- THIS KIT IS INTENDED FOR VEHICLES USING A FIXED FLANGE OUTPUT (EXTENSION HOUSING) THAT DO NOT REQUIRE THE DISC PARKING BRAKE. THIS SPACER IS THE SAME THICKNESS OF THE PARKING BRAKE DISC, ALLOWING THE SAME DRIVESHAFT LENGTH TO BE IMPLEMENTED.
- DO NOT INSTALL ANY DRIVELINE COMPONENTS THAT SHOW SIGNS OF MANUFACTURING DEFECTS OR SHIPPING/HANDLING DAMAGE.
- FIXED FLANGE OUTPUT YOKE PROTOTYPES HAD M10X1.5 THREADS, IN THESE CASES USE 4X TRN7526 (M10X1.5X35MM FLANGED HEX BOLT).

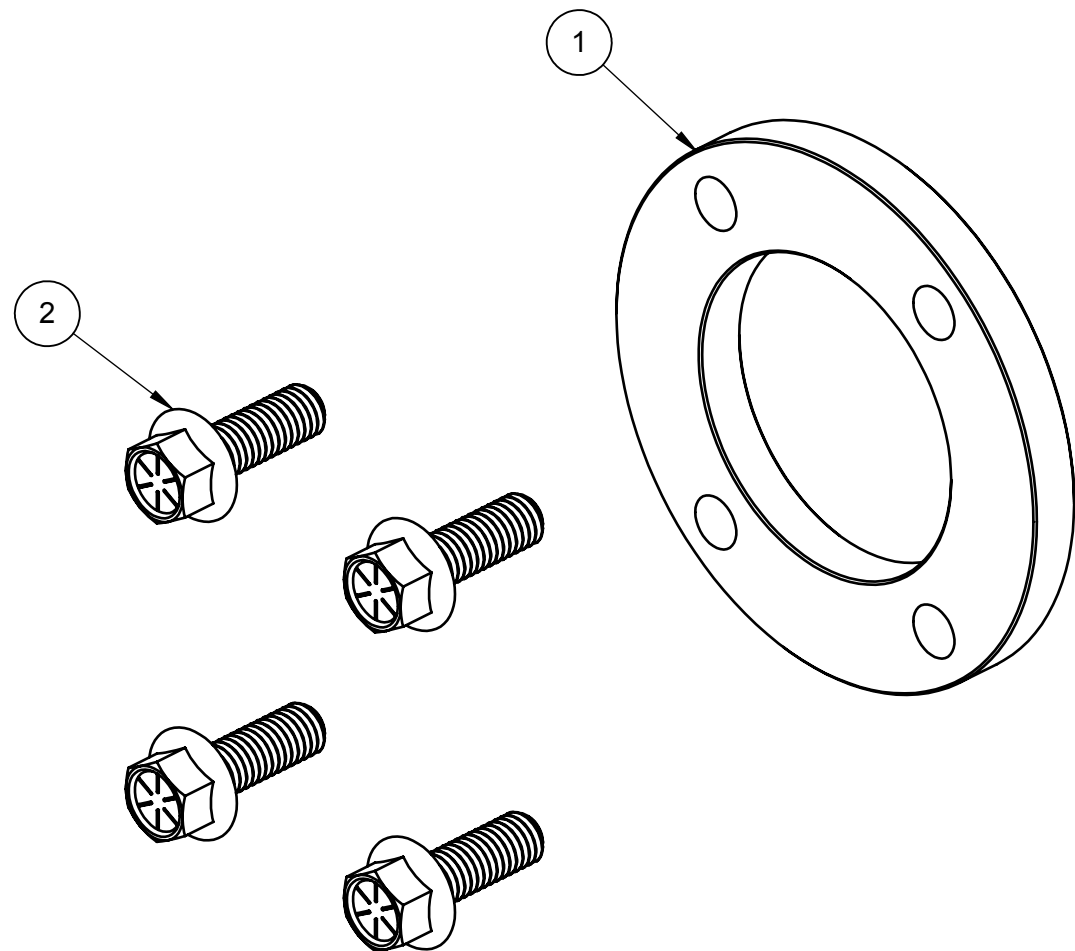
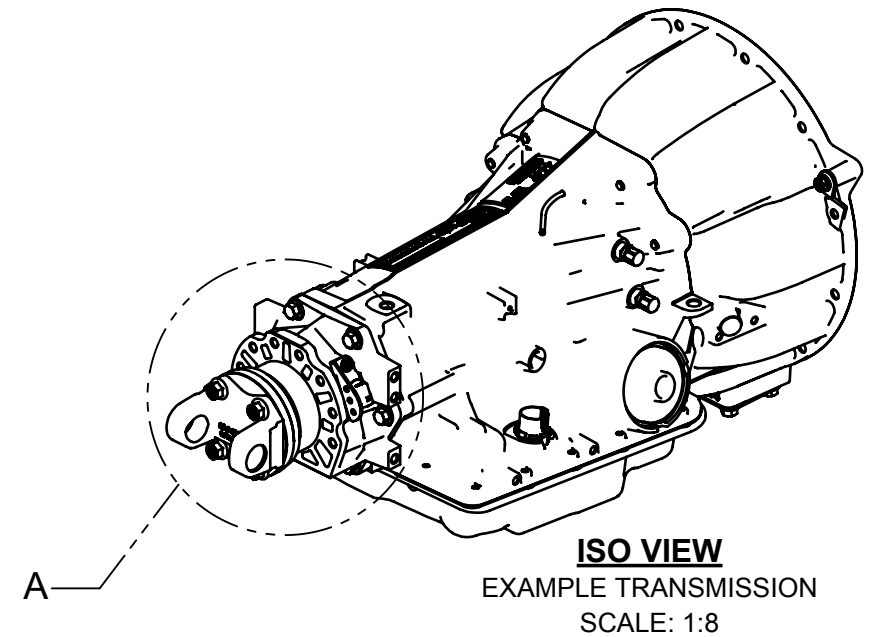

**EXPLODED VIEW**  
KIT COMPONENTS  
SCALE: 2:3

APPLY THREADLOCKER.  
TORQUE TO 65±5 N\*m.

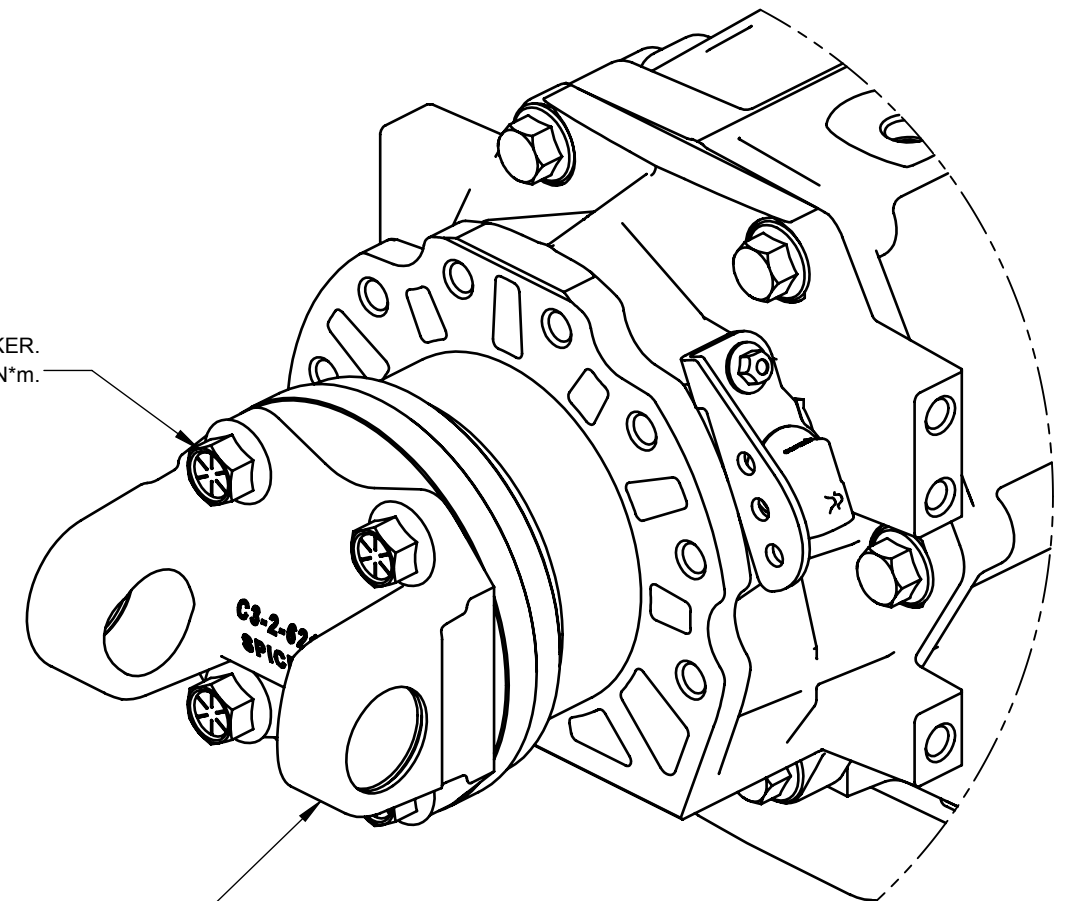

EXAMPLE U-JOINT YOKE SPICER 3-2-159 SHOWN.  
DRIVESHAFT COMPONENTS NOT SUPPLIED BY PCS.



DESCRIPTION  
**SPACER KIT,  
FIXED FLANGE OUTPUT**

**PROPRIETARY AND CONFIDENTIAL**  
THE INFORMATION CONTAINED IN THIS DRAWING IS THE SOLE PROPERTY OF PCS. ANY REPRODUCTION IN PART OR AS A WHOLE WITHOUT THE WRITTEN PERMISSION OF PCS IS PROHIBITED.

|                          |                         |
|--------------------------|-------------------------|
| USED ON                  | NEXT ASSEMBLY           |
| DRAWN BY                 | MFP 12/7/2017           |
| ENG APPR.                |                         |
| DIMENSIONS ARE IN INCHES | SCALE: 1:2 SHEET 1 OF 1 |

|          |                |          |
|----------|----------------|----------|
| SIZE     | DRAWING NO.    | REV      |
| <b>B</b> | <b>BRK2021</b> | <b>1</b> |