

BOM #	DESCRIPTION	PCS PART #	QTY
1	SAE4 TO SAE3 ADAPTER PLATE	TRN7710	1
2	BOLT, M10X1.5X25mm FLANGED HEX	TRN7500	12

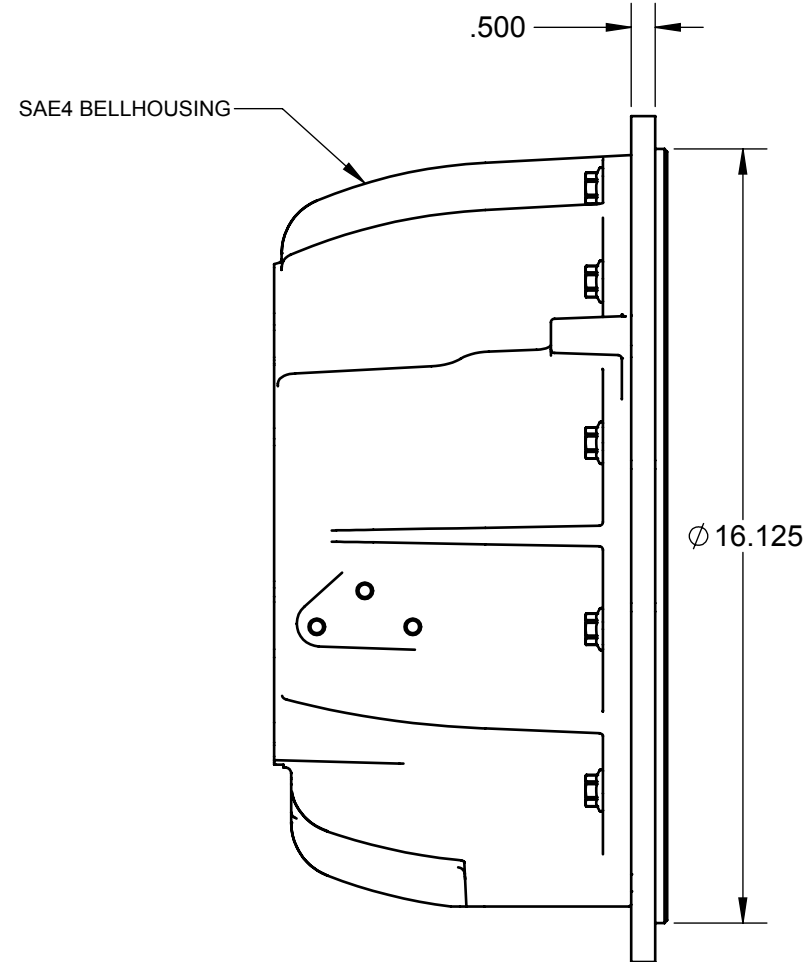

SIDE VIEW
ASSEMBLED
SCALE: 1:4

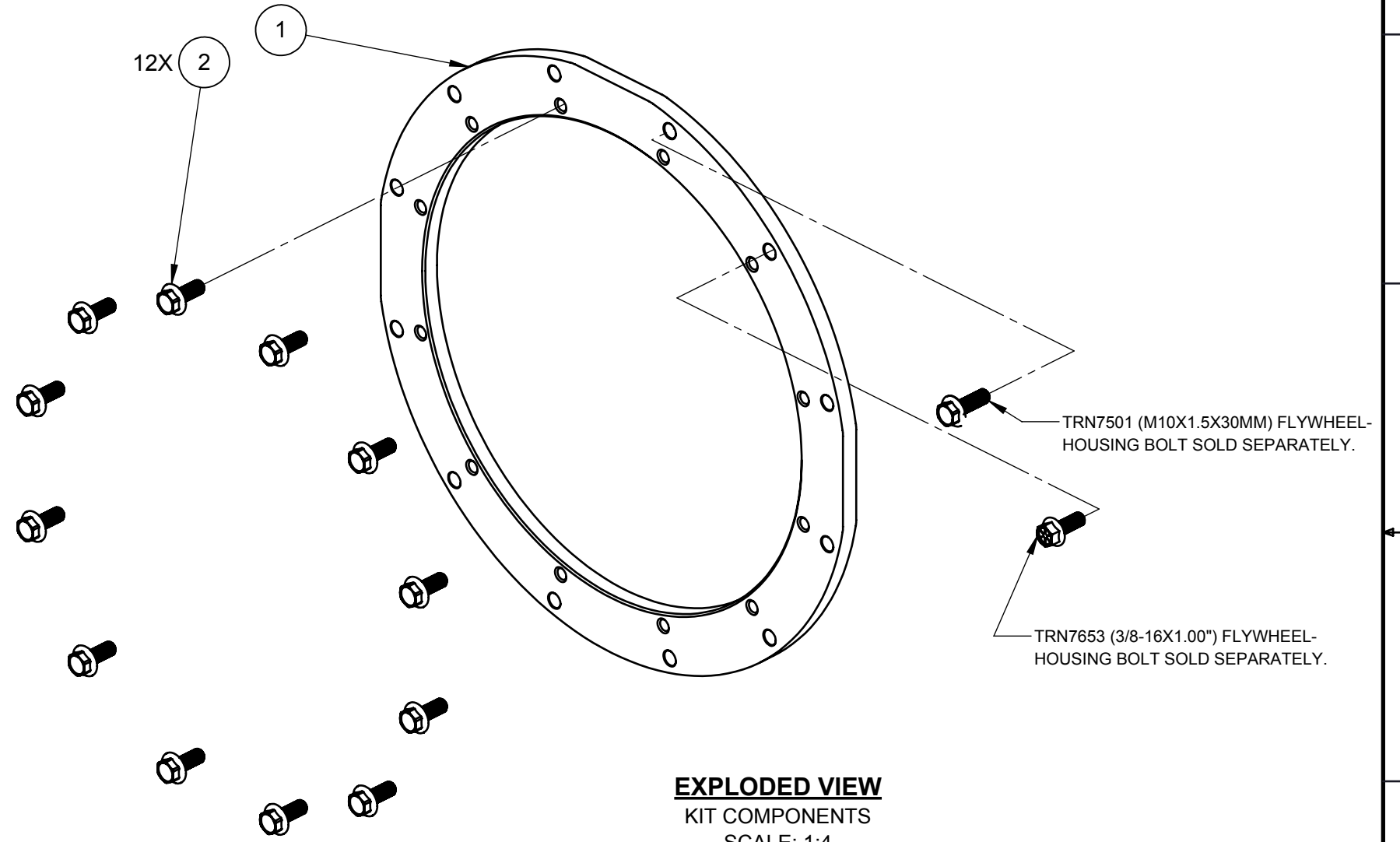

EXPLODED VIEW
KIT COMPONENTS
SCALE: 1:4

NOTES:

1. INTERPRET THIS DRAWING IN ACCORDANCE WITH ASME Y14.5-2009.
2. THIS KIT IS INTENDED FOR ADAPTING ENGINES WITH SAE3 FLYWHEEL-HOUSING INTERFACES TO TRANSMISSIONS WITH SAE4 BELLHOUSING INTERFACES.
3. DO NOT INSTALL ANY DRIVELINE COMPONENTS THAT SHOW MANUFACTURING DEFECTS OR SHIPPING / HANDLING DAMAGES.
4. FLYWHEEL-HOUSING INTERFACE BOLTS ARE NOT SUPPLIED WITH THIS KIT, BUT ARE AVAILABLE SEPARATELY. REFERENCE YOUR FLYWHEEL-HOUSING FOR CORRECT THREAD PITCH AND DEPTH.



DESCRIPTION
SAE4 TO SAE3 ADAPTER KIT

PROPRIETARY AND CONFIDENTIAL
THE INFORMATION CONTAINED IN THIS DRAWING IS THE SOLE PROPERTY OF PCS. ANY REPRODUCTION IN PART OR AS A WHOLE WITHOUT THE WRITTEN PERMISSION OF PCS IS PROHIBITED.

DRAWN BY	MFP	4/9/2018
ENG APPR.	JJK	4/9/2018
DIMENSIONS ARE IN INCHES		SCALE: 1:8 SHEET 1 OF 1

USED ON	NEXT ASSEMBLY
SIZE	DRAWING NO.
B	TRN8379
REV	1