

BOM #	DESCRIPTION	PCS PART #	QTY
1	AUXILIARY TRANS COOLER		1
2	-6ORB TO -6JIC FITTING	TRN0212	2
3	M6X1.0X20mm FLANGED HEX BOLT		2
4	M6 WASHER, OVERSIZED		2

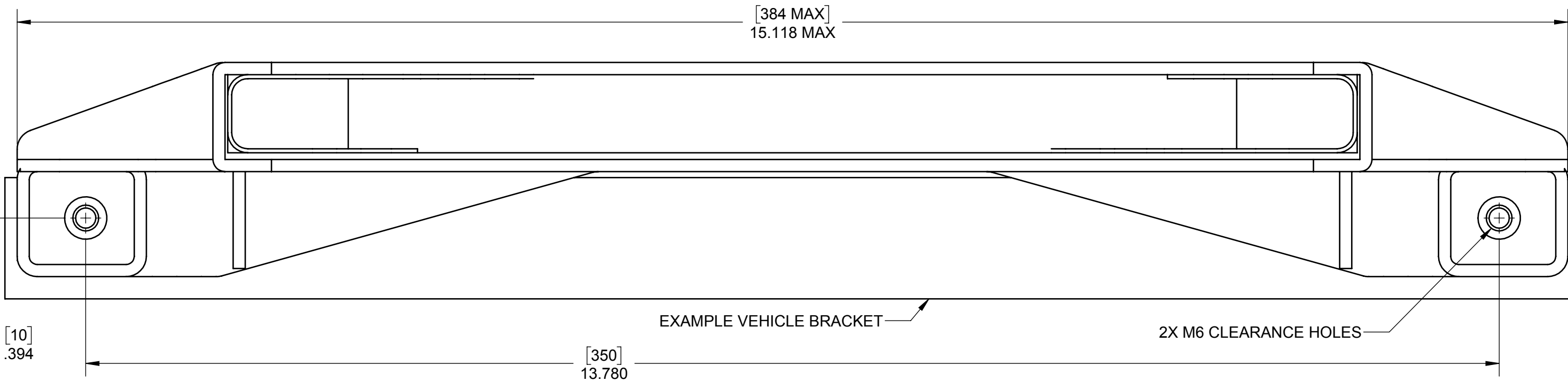
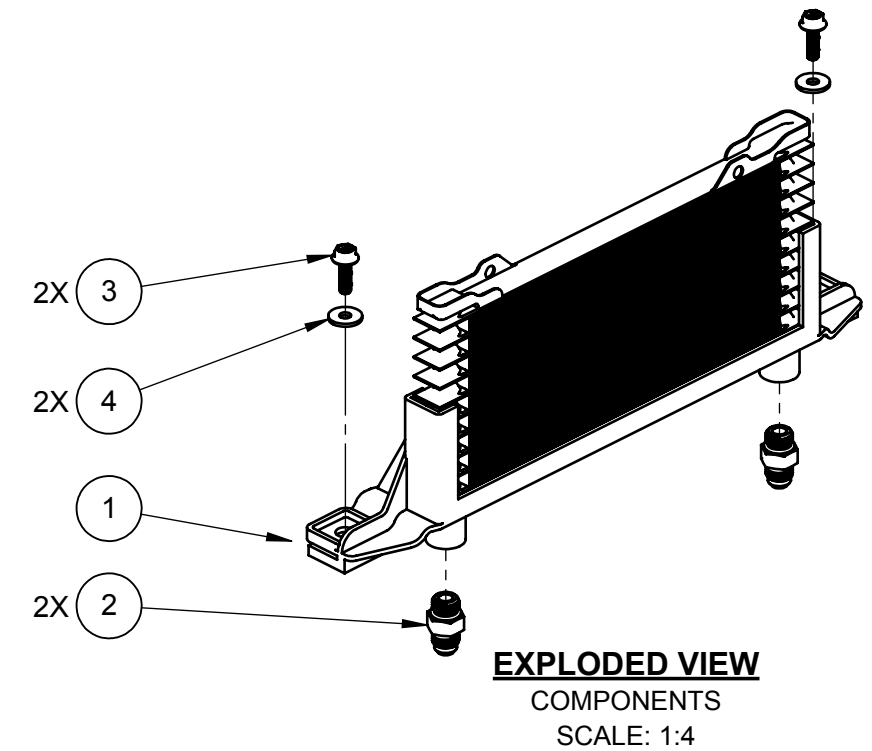

TOP VIEW
INSTALLED - TEMPLTE
SCALE: 1:1

NOTES:

1. INTERPRET THIS DRAWING IN ACCORDANCE WITH ASME Y14.5-2009.
2. DO NOT INSTALL ANY SYSTEM COMPONENTS THAT SHOW MANUFACTURING DEFECTS OR SHIPPING / HANDLING DAMAGES.
3. USE ONLY DEXRON-VI (6) TRANSMISSION FLUID.



DESCRIPTION
AUXILIARY TRANS COOLER KIT

PROPRIETARY AND CONFIDENTIAL
THE INFORMATION CONTAINED IN THIS DRAWING IS THE SOLE PROPERTY OF PCS. ANY REPRODUCTION IN PART OR AS A WHOLE WITHOUT THE WRITTEN PERMISSION OF PCS IS PROHIBITED.

DRAWN BY	MFP	4/23/18
ENG APPR.
DIMENSIONS ARE IN INCHES SCALE: 1:4 SHEET 1 OF 1		

USED ON	NEXT ASSEMBLY	
SIZE	DRAWING NO.	REV
B	TBD	1